



# Large Whale Gear Research Summary

November, 2002

## Table of Contents

### Gillnet Research

#### Page

1. In Situ Observations of Commercial Demersal Gillnets In situ observations of commercial gear were undertaken in waters located off the Massachusetts coast. The vertical profile of the gillnet observed during this investigation is typical of other bottom tending gillnets that are commonly set for round groundfish.
3. Land Testing of Gillnet Modifications A section of gillnet was loaded to simulate a whale while loads were measured in both the floatline and leadline. Weak link devices tested included knotted line, light line, plastic links, and "Chinese fingers". The breaking strength of 6.5" and 7" 14 gage monofilament webbing was also tested. This land testing demonstrated that weak links placed in the floatline will fail, when a force is applied, and will release tension on the floatline as long as the gear offers enough resistance to allow the breaking strength of the weak link to be exceeded.
23. Low Strength Floatline Ten nets were built, 5 with 1/8" floatline and 5 with 3/16" floatline. These nets were used by fishermen and fished along with their typical gear. Significant problems were encountered handling the nets, as the small diameter floatline kinked and dipped through the meshes so badly that the gear was soon unfishable.
23. Gillnets with 6 Weak Links per Net Twenty nets were built with 1100 pound weak links installed in a traditional type of floatline at 8 fathom intervals. The construction techniques used for these nets eliminated the handling problems associated with the 1/8" & 3/16" floatline nets previously constructed.
24. Mega-Float Gillnets In 1999 10 gillnets were built incorporating a new type of floatline called *Mega-Float*. This floatline is constructed with internal flotation to eliminate the need for external floats along the length of the net. The elimination of the external floats would reduce the chance of the floatline getting hung up in a whale's baleen. The buoyancy of the mega-float floatline is about 15% less than traditionally rigged nets and is probably why some feedback from testing indicated the nets did not fish as well as traditional gear.
26. Weak Links in Gillnet Floatlines In the Summer of 2000 eighty nets were built utilizing 3 different strength weak links (600, 900 & 1100 lb.) Each net contained

three weak links of the same strength, equally spaced along the floatline. These nets have been deployed in the Great South Channel and throughout the Gulf of Maine for one complete fishing season (12 months) with less than a dozen failures reported out of the 180 weak links tested. Reports of failures have been mostly when gear has been caught down on the bottom and lead line has already parted. Link failures have spanned all of the 3 sizes of weak links with the 600 lb. Link registering over 75% of the failures.

27. Low Breaking strength line The NMFS Gear Research Team and the NMFS South East Region are currently contracting with cordage companies and polymer experts to develop a low breaking strength line to be used in the float line of sink gillnets. The challenge is to develop a line with the same diameter, floatation and stretch ratios as the line currently used, but with a reduced breaking strength ( 600 - 1100 pounds). Experimental line is expected to be available for at sea testing in gillnets by Spring 2002.

Next Generation Floatline Weak Link A manufacturer has developed a weak link that is inexpensive and easy to install on existing or new gear. This weak link design is also being developed for use in other areas of the gear.

28. Gillnet Experiments in the Bay of Fundy Load cells were utilized for measuring loads in gillnet gear aboard 3 commercial vessels while hauling and setting the gear.
32. Other Gillnet Load Cell Work A variety of measurements have been collected in various portions of gillnets during hauling, setting and fishing activities.

Development of Gillnet Friendly Load Cells Redesign of existing underwater load cells into a package more suitable for deployment on gillnets is ongoing.

### *Lobster Gear Research*

33. Load Measurements in Lobster Gear A variety of measurements have been collected in various locations of lobster gear during hauling and setting activities.
34. In Situ Measurements of Loads in Buoy Systems Load cell data collected from deployments in the offshore & near-shore lobster fishery as well as the gillnet fishery.
35. Loads Measured While Towing a Variety of Buoys and Buoy Systems
36. In Situ Observations of Lobster Gear In situ observations of lobster gear were undertaken in waters located off the New England coast. Observations of composite buoy lines (sinking at the surface & floating at the trap end) as well as ground lines composed of floating rope and sinking rope were documented. The buoyline exhibited vertical profiles near the bottom and surface while the attitude

41. The Design, Testing and Production of Mechanical Weak Links for Fishing Gear, P. Anderson, Ohio State University. Development of two types of weak link devices - 1) Flat link, manufactured from high molecular weight polyethylene, and 2) a *lap-joint* weak link, manufactured using flexible, adhesive lined, polyolefin tubing that shrinks to 1/3 the original diameter when heated. The flat links could be manufactured to appropriate tensile strengths however, they did not perform well under torsional and bending loads. The *lap-joint* weak links revealed that failure loads ranging from approximately 450 pounds to over 1200 occurs, depending on the number of layers of tubing, the length of the lap joint, the test temperature, and the rope material, diameter, and condition.
53. Design, Testing and Evaluation of an Acoustic Release System for Offshore Lobster Pot Lines, J. DeAlteris. Project was to develop a cost effective prototype acoustic release system for the buoy end line of offshore lobster gear. The final product was a prototype system that carries 1000 feet of hauling rope and will operate in depths up to 600 feet. The system was successfully tested at sea aboard lobster vessels in the Gulf of Maine and demonstrates proof of concept.
70. Development of Bottom Weak Links and Buoy Line Messenger System, R. Smolowitz and D. Wiley. Work to develop a weak link device that is time (as opposed to force) sensitive. This delayed release device would allow the gear to be hauled for a pre-specified period of time before releasing. The messenger system is patterned after the common oceanographic practice of sending a weighted device down a line to perform a function at the bottom of the ocean. In this application the device would provide a way to send a heavy hauling line down a light, easily broken "tag" line that is attached to the gear. Once the messenger is attached to the gear, the hauling line is used to retrieve the gear.
93. Force Measurements of Rope Sliding Through Baleen Measurements of forces required to pull ropes of various diameters through baleen plates were conducted in the laboratory and in-situ for several species, including blue whale, humpback, and right whales.
94. Weak Link & Buoy Line Marking Techniques.
97. Weak Link Tests Laboratory testing of various weak link techniques including: knots, hog rings, wooden toggles, cutting one strand, various buoy stick attachment techniques, plastic cable ties, etc.
101. Estimation of the Tractive Force for the Northern Right Whale, A. Fridman, D. Williams, J. Guimond, & J. DeAlteris. This report develops estimates of the propulsive and tractive forces that a right whale would be capable of. Maximum propulsive force estimates ranged from 465 pounds for a 13 foot whale to 9440 pounds for a 60 foot whale at 20 knots. Maximum estimates of tractive force determined by the method of Fridman, ranged from 135 pounds to 6969 pounds for the same species and size range.

Development of "Off-the-Shelf" Weak Links Supported the development and production of weak links that would make 500, 600 & 1100 pound off-the-shelf weak links available to industry.

132. Gear Retrieval Utilizing a Light Buoy Line A light (weak) buoy line is used to mark the gear as well as to retrieve the hauling line that is stored at the bottom with the gear. The light buoy line only needs to be strong enough to hold the buoy to the gear, thus it would pose a minimum threat to marine mammals.

### *Research Outside NMFS*

134. The Design, Production and Sea Testing of Modern Mould Sliplink™ Knotless System, D. Paul and G. Ostrom. Development and testing and production of a knotless weak link system. Initial design resulted in units with load ratings 150 to about 250 pounds. Redesigned to a unit with a 400 pound load rating.

142. Collaborative Research to Design Modifications of Fixed Fishing Gear for Reducing the Risk and Consequences of Right Whale Entanglement, D. Wiley, R.J. Smolowitz, R. MacKinnon, S. MacKinnon

Acoustically Triggered Buoyless Lobster Trap Recovery System, Sea Grant, NH/ME. Design and development of a prototype acoustic buoy release system.

Photo Degradable Rope Development, D. Allen. eubalaena award

Development of a Breakaway Unit for Lobster Pot Buoy Lines, E. deDose

Use of Light and Illuminated Ropes to Prevent Right Whale Entanglement, S. Kraus

Operational Testing of a Low Strength Weak Link for Surface Buoys and a Knotless Line Fastener for Reducing the Risk and Consequences of Right Whale Entanglement, S. MacKinnon

Gear Modification to Address Right Whale Entanglement, G. Ostrom

Design of a Whale Safe Buoy, C. Goudey

This collection of information represents research conducted by the NOAA Fisheries, Northeast Regional Office, Protected Resources Division, Gear Research Group, unless otherwise noted. This is the 2<sup>nd</sup> edition, November, 2002. As new research becomes available, it will be added to this volume. For updates, additional copies, questions, comments, etc, contact:

John Kenney  
P.O. Box 228  
Kingston, RI 02881  
(401) 294 - 0443  
[John.F.Kenney@noaa.gov](mailto:John.F.Kenney@noaa.gov)

OR:

Glenn Salvador  
12 Gosling Drive  
Lewes, DE 19958  
(302) 644 - 2375  
[Glenn.Salvador@noaa.gov](mailto:Glenn.Salvador@noaa.gov)

Additional information can be found at the ***“Atlantic Large Whale Take Reduction Plan”*** web site:

<http://www.nero.nmfs.gov/whaletrp/>

## In Situ Observations of Commercial Demersal Gillnets

H. Arnold Carr  
Massachusetts Division of Marine Fisheries

**Introduction:** In situ observations of commercial demersal gillnet gear was undertaken in waters located off the Massachusetts coast. Similar gear is found in or adjacent to waters deemed critical habitat for endangered marine mammals such as the Right Whale.

**Purpose:** To ascertain the in situ functional attributes of commercial gillnets so as to determine the potential to entangle marine mammals and to provide an understanding toward possible approaches to mitigate this potential.

This investigation is considered part of a primary response resulting from a series of meetings with NMFS and the commercial fishing community. The meetings discussed the potential for entanglement of Right Whales in commercial lobster and gillnet gear and avenues of possible mitigation. The gear is sometimes abundant in areas deemed critical habitat for this species. This investigation addresses the issue of how this fishing gear lies in situ; determining this will greatly assist ascertaining the means to reduce entanglement of endangered marine mammals.

**Methods:** A team including a biologist, gear technologist and commercial fishermen combined with remote operated vehicle (ROV) equipment ventured out on a commercial gillnet vessel off the coast of Massachusetts. The team observed static commercial gillnet gear set under commercial conditions. A commercial gillnetter voluntarily provided vessel support.

**Results:** The ROV was deployed at sea for one day. The day was spent in Massachusetts Bay as the vessel operated from the North River, Marshfield. The bottom that the net was set was about 70 feet deep and it consisted of primarily cobble. No tidal current was noticed.

The commercial gillnet that was set matched the typical gillnet set by New England fishermen (see section entitled "Description of New England fishery" below). Observations taken by the ROV showed that the gillnet had a nominal vertical profile of ten feet. The floatline was essentially horizontal at this altitude. The only exception was where the net was caught in some rocks and may have been also caught by the anchor. In this situation the floatline varied in altitude off the bottom. The floatline had a low altitude of 8-9 feet between the floats and a high altitude of 13 feet at some of the floats.

**Discussion:** The observed gillnet that was undisturbed had a vertical profile similar to other commercial gillnets that have been observed by those scientists and fishermen aboard the vessel on that one day. The nets do form a wall and are vertical in profile except when a tidal current is present. The current reduces the altitude of the net. This reduction is related to the direction and velocity of the current, the amount of floatation and leadline on the net, and, to some degree, the characteristics of the webbing.

Visually, the monofilament webbing was near invisible when observed on a horizontal plane. The webbing appears dark when looking up toward the water's surface and light when contrasted against the darker seabottom.

### Description of New England fishery

The New England Demersal gillnet fishery consist of approximately 100 vessels (~50 being part-time). In 1992, the sink gillnet fishery was the 2<sup>nd</sup> largest groundfish harvesting industry in the northeastern United States, with annual landings of 17,000 metric tons worth \$16 million. In 1998 it was about 21,000 metric tons worth about \$22 million. Fishermen currently are able to fish only 88 days in a fishing year if they hold a Federal fisheries permit. Previously fishermen have been able to fish on underutilized fisheries (such as dogfish and monkfish) while not using their days at sea. That freedom is beginning to change.

The type of gear used for groundfish, consist of 6-8" mesh with a twine size of #8(0.47mm) to #14(0.62mm) (for dogfish) usually 20-25 meshes deep. For skates and monkfish, the gear consist of 10-14" mesh with a twine size #8(0.47) to #10(0.52mm) usually 20 meshes deep. On the average, fishermen may use ~60 nets if fishing inshore and ~100 nets if fishing offshore.

### Discussion

The vertical profile of the gillnet observed during this investigation are typical of other bottom tending gillnets that are commonly set for round groundfish. Flat fish, such as flounder, and monkfish are usually targeted by gillnets that have a very low vertical profile or lie more on the bottom. The apparent potential for entanglement for the gillnets that target roundfish, such as cod and haddock, can be best mitigated through weaklinks on the floatline, or acoustic pingers (possibly) on the nets. This would require further work.

Another known entanglement potential lies with the monofilament webbing that makes up the body of the net. Gillnets catch fish in the fish capture process three ways: gilling, wedging and entangling. The possible nature of a whale encountering the gillnet can easily set forth the process of a simple entanglement of some monofilament webbing. This simple entanglement can escalate into a more complex entanglement if the behavior of the whale is to roll after an initial encounter with a gillnet. This behavior and problem has been a topic of frequent discussion and the potential for this, given a ten foot vertical profile wall of netting, as observed in these underwater investigations confirms this potential.

The last potential part of the gillnet gear that could entangle has already been identified, the vertical buoy line. This is already a continued focus of ongoing mitigative work.



# Land Testing Of Gill Net Modifications

Prepared by

**Ronald Smolowitz**  
Coonamessett Farm

and

**David Wiley**  
International Wildlife Coalition

In Association with

John Our, Cape Cod Gill Netters Assoc.  
Robert MacKinnon, Mass Bay Gill Netters Assoc.  
Bruce Ambuter, Ambuter Consultants  
Henry Milliken, Mass Div Marine Fish.  
John Kenney, NMFS

Prepared for

National Marine Fisheries Service  
Gloucester, Massachusetts

January, 1998

## Land Testing Of Gill Net Modifications

### Abstract

Three days of largely empirical land testing of gill net modifications were conducted to examine potential means to reduce whale entanglement. More than two dozen trials were conducted in which loads were recorded on each end of the float line and lead line as well as the simulated whale loading. Weak link devices tested included knotted line, light line, plastic links, and "Chinese fingers". The breaking strength of 6.5 and 7.0 inch, 14 gage, monofilament webbing was also tested.

### Introduction

The northern right whale (*Eubalanea glacialis*) is the most critically endangered large whale in the world, and is protected under the Endangered Species Act (ESA). The western North Atlantic population is estimated to be approximately 300 animals. In 1995, the re-authorized Marine Mammal Protection Act (MMPA) mandated that the kill of northern right whales from interaction with commercial fishing gear be reduced to zero. In September 1996, a Federal District Court in Massachusetts issued an injunction which ordered the Massachusetts Division of Marine Fisheries (MDMF) to develop a proposal to restrict, modify, or eliminate the use of fixed fishing gear in waters of Massachusetts considered right whale critical habitat, including most of Cape Cod Bay.

Some measures proposed to minimize the entanglement of right whales with fixed fishing gear include area/time closures and/or modification of the gear. Unfortunately, so little is known about the entanglement mechanism and behavior of the whales, that some of the protective measures under consideration could put fishermen out of business without solving the problem for the whales. It is imperative to find solutions which eliminate entanglement and keep fishermen in economically sound operations.

Surface buoys and buoy lines are used to mark the location of fixed gear including lobster traps and gill nets. Whales may become entangled in buoy lines and with nets and lines on the ocean bottom. It is surmised that when the animal encounters a line, it may move along that line until it comes up against something such as a buoy. The buoy can then be caught in the baleen, against a flipper or on some other body part. When the whale feels the resistance of the gear, it thrashes, which may cause it to become entangled. The vulnerability of whales to entanglement in gill nets may vary by species, local, and season. Many ideas have been proposed to solve the entanglement problem and there has been considerable discussion of the question by fishermen, biologists, and gear technologists.

This project is part of the gear research aimed at solving the entanglement problem. The specific projects were formulated by the NERO Large Whale Gear Advisory Group (LWGAG) in June, 1997. The group consisted of representatives of the fishing industry, federal and state governments and independent whale research organizations. One of the concerns expressed at the meeting was a lack of knowledge of loads on a gill net that are necessary for a whale to break loose from lines or webbing. Initial tests on a gill net, funded by the Massachusetts Environmental Trust at Coonamessett Farm, revealed some of the dynamics which will impact the choice of gill net design and rigging aimed at minimizing entanglement risk. The tests indicated that existing methods of hanging gill nets may negate the effectiveness of weak links in the bridles of the net. Continued testing of gill net modifications was recommended in order to overcome the problems with operation of the weak links.

The research described in this report focuses on rigging and land testing a gill net with weak links positioned in a manner that would potentially reduce the risk of entangling a whale encountering the gear. A 150 foot section of gill net was tested by simulating a whale encounter with the gear and recording the loads at each end of the net section. Several different designs for weak links were tested and the testing was video taped. Land testing of gill nets is a low cost first step in examining gear modifications.

### **Previous Research**

In January, 1997 the International Wildlife Coalition (IWC) received a grant from the Massachusetts Environmental Trust to develop and test snag-free fishing gear for use in reducing right whale entanglement and mortality. The IWC research team consisted of members from the IWC (whale biologists), Coonamessett Farm (gear technologists), and the Massachusetts Lobstermen's and Massachusetts Bay Area Gill Netters Associations (fishermen). One aspect of the research program was the development of a means of surface buoy attachment that would break free without snagging a whale that came into contact with the buoy. After considerable research, a method was devised using hog rings to attach the buoy line to the buoy (Wiley et al, 1997). With a satisfactory working solution to this aspect of the entanglement problem, the research project began to focus on the gill net itself.

Bottom sink gill nets used in the new England groundfishery are 300 feet (91 m) in length, 8 feet (2.4 m) to 12 feet (3.7 m) in height, and are set end to end in strings of nets up to 6000 feet (1,828 m) in length (Figure 1). Each net consists of a float line and a lead line to which monofilament webbing is attached or "hung". The webbing in the groundfishery typically ranges from 6 to 8 inches in mesh size and is mostly 14 gage thickness. At the end of each net the float line attaches to the lead line forming bridles to which the next net in the string is attached. The end nets of the string are anchored and attached to the surface buoy line.

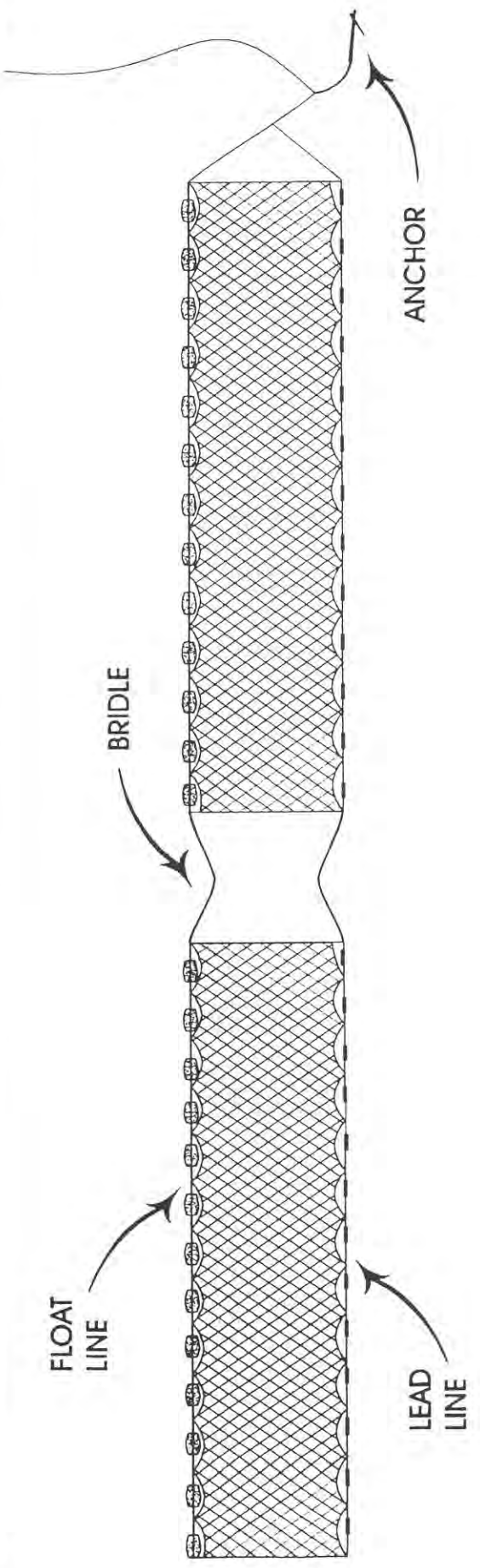
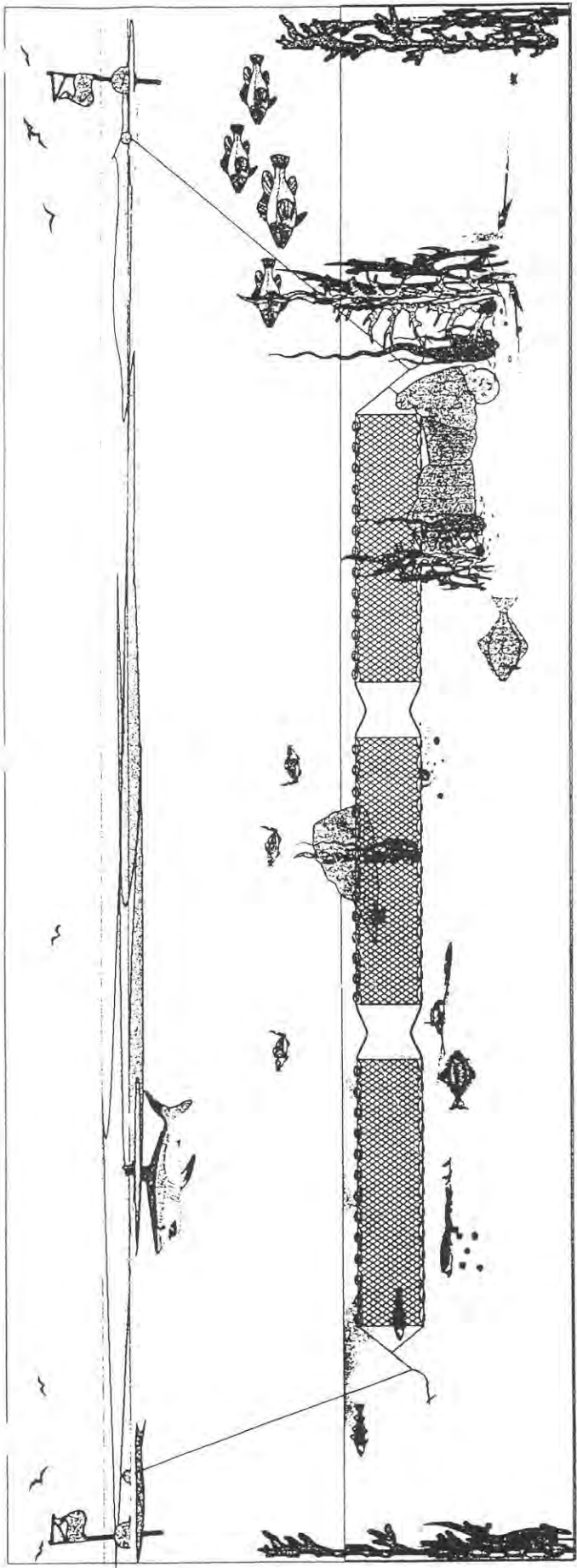

FLOAT  
LINE

BRIDLE

LEAD  
LINE

ANCHOR

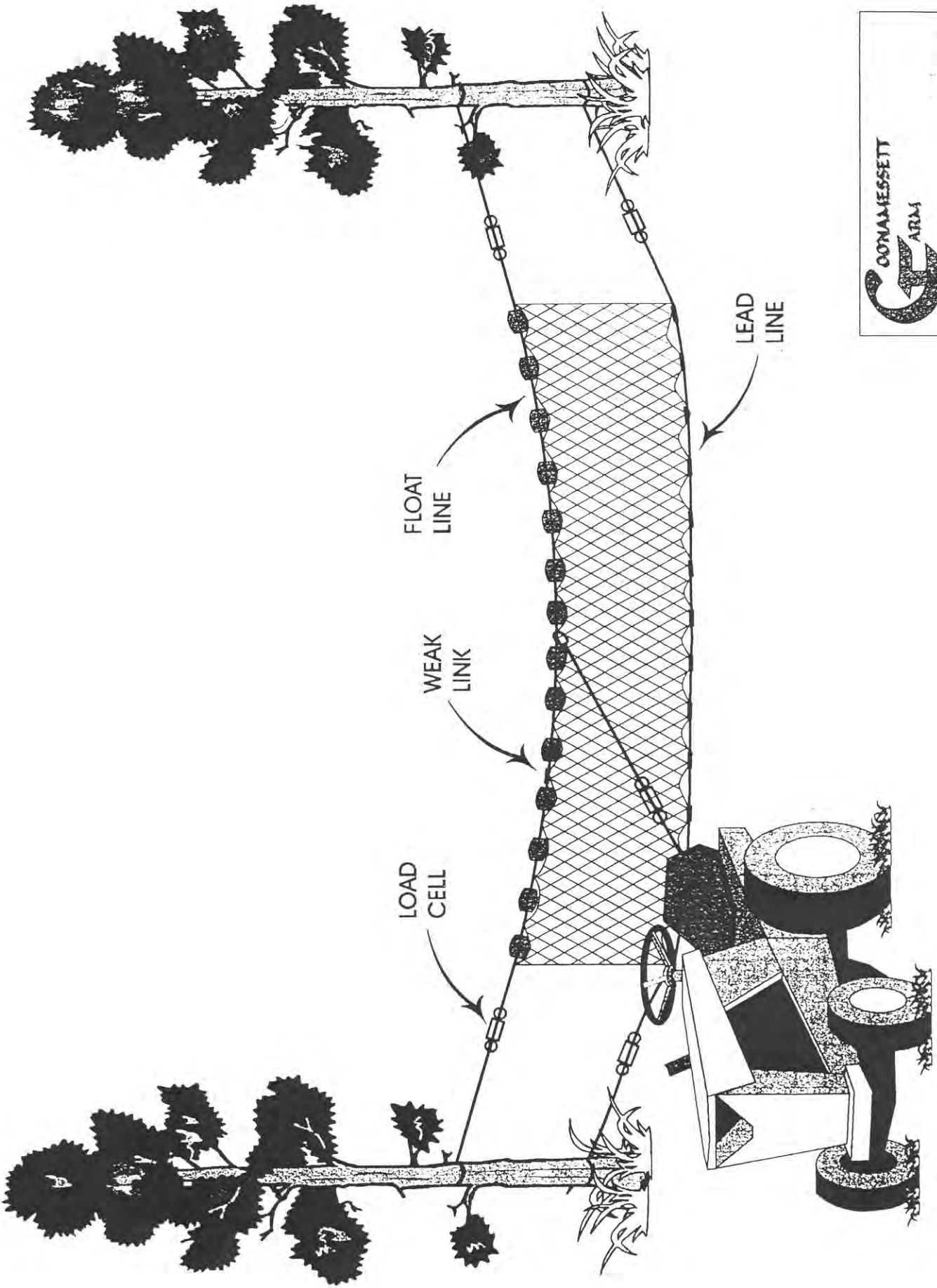

**CONNESSETT**  
**ARM**

LAND TESTING of GILL NET ©

drawn by: Robln Amaral      date: 12/28/97

A land-based dry testing site for gill nets was established at Coonamessett Farm to observe and record the behavior of gill nets subjected to whale-simulated loads. Load cells were attached to points on the nets and the line towing the simulated whale model through the nets (Figure 2). The tests provided information on the forces acting on the nets and the breaking points of modifications. The following discussion highlights some of these observations from Wiley et al. (1997).

#### Float line resistance

One mechanism of entanglement is that a whale might hit the vertical “wall” of the gill net and become entangled in the net as the net wrapped around the whale’s body. One proposed approach to minimize this risk is to lower the buoyancy of the float line and increase the anchoring/weight of the lead line and/or ground tackle (bottom holding capacity). The concept here is that the whale would be able to push over the net without getting entangled. In the land-based testing approach this situation was modeled by adjusting the tension in the float line while dragging a mesh bag of large plastic balls (maximum breadth 72 inches/1.8 meters) over the float line. The test demonstrated that when there was low tension in the float line, the bag of plastic balls was less likely to snag. However, when the tension was high there was a high probability that the bag would be hung up on the float line.

This test indicated that it may be a valid approach to lower float line buoyancy and/or raise bottom holding capacity. It further supported the hypothesis that if the float line broke early in an encounter there was a decreased chance of entanglement.

#### Catenary formation

The land testing identified another possible mechanism that may increase the likelihood of entanglement. When even low loads, several hundred pounds, are applied to the float line or webbing the net begins to form a large catenary. This bowing of the net around a striking whale may cause entanglement before enough force is generated to break free of the net. The factors that would affect this catenary forming process include the speed of the encounter, the length of the net string, the bottom holding capacity, and the ability of the lead line to move freely over the bottom without snagging. Bottom holding capacity is a function of the nets anchoring system and substrate. The ability of the net to move over the bottom freely is a function of bottom topography. The speed of encounter is an important variable because the resistance of the net, and thus the forces generated in the float line, is exponentially related to the movement of the dragged gear through the water.

### Weak link location at bridles

One proposed solution to make nets less likely to snag whales has been to place weak links between each net at the location of the bridles. Tying the nets together with a weak link inserted at the top bridle connection would not damage the integrity of each net on the string. Testing demonstrated that this approach did not work because when the link failed the load was transferred to the section of vertical float line that connects to the lead line at each net end. The end result was that the float line still remained taught under the simulated whale load.

### Weak link design

These initial land tests were not designed to test a variety of weak link designs. Plastic swivels (270 lb breaking strength) and flat plastic plates with reduced cross-section areas (250 and 450 breaking strengths) were utilized at the bridle location. One important observation made was that as load was applied there was some twisting of the bridle creating torque loads on the flat weak links. As a consequence, these links failed below their designed breaking strength.

The results of the weak link tests at the bridle location lead to the belief that it may be a better approach to insert the weak links into the float line within the net itself. A disadvantage of this approach is that if the link accidentally fails the webbing will tear requiring replacement of the net. Another consideration with this approach is that the link has to be designed so that it will not snag on the webbing creating problems in setting the gear.

The testing did not evaluate the idea of placing a weak link in the lead line in addition to the float line. Having a weakened lead line would create problems for the fisherman trying to retrieve his gear. More importantly, it is not certain that a weakened lead line would improve the situation for an encountering whale. Instead of pushing over or breaking through the gear, a weakened lead line might allow the whale to carry the gear away.

### Webbing strength

The strength of the webbing itself was tested by pulling the bag of plastic balls through the mesh. The irregular shape of the bag provided for uneven distribution of loading on the twine. To compensate for uneven loading, the tests were also conducted with a 48 inch (1.2 m) diameter disk for uniform stress distribution and replication. In either case relatively low loads, on the order of 250-300 pounds, were needed to break through the twine. Even at these low loads, a significant catenary was formed.

### Instrumentation requirements

Instrumentation proved to be one of the biggest difficulties in conducting these tests. The digital output of the load cells had to go through an interface and into the data logger. There was no real-time display of the loads due to equipment problems and lack of software. These trials indicated a need for real-time viewing of the loads coming from each sensor.

### **Methods**

The project followed similar procedures to that in the previous land-based testing discussed above. The focus was on inserting different weak link devices into the float line of the hanging gill net section and to record the loads and gear behavior. The maximum loads that we could safely record on the load cells had to stay below 1000 lbs. We decided to target breaking strengths of approximately 500 lbs for weak link design to stay within our equipment's working range. The load was applied by using a tractor that was directly tied to the float line via a load cell.

### Instrumentation

The load cells were the same ones used in the previous testing; Model SM-1000 Super-Mini Load Cells with rod-end bearings from Interface, Inc. (Scottsdale, AZ). These load cells were chosen because of their low cost, highly linear output, and suitability for non-submersible applications. The load cells were connected to the data logger with dual shielded twisted-pair instrumentation cable (Belden # 8723).

The data logging instrumentation differed significantly from the first test series. The data logger used was a prototype version designed for evaluating bridge deck parameters. We leased this unit to record the testing and also to aid in evaluating future data logger design for this type of fishing gear work. The unit consisted of a 16 channel differential multiplexor, a programmable pre-offset gain amplifier stage (for gains of 1x, 10x, 100x, and 1000x), a programmable offset circuit (producing voltages from -4 to +4 volts in 2 millivolt increments), and a programmable post-offset gain amplifier stage (for gains of 1x, 2x, 4x, and 8x).

The DC offset produced by the first amplifier stage is nulled out by the offset cancellation circuitry. The post-offset gain stage allows further gain as required. The output of the second stage amplifier is fed to the 12 bit A/D converter of the Model 8 Tattletale (Onset Computer, Inc.). The Model 8 Tattletale performs the functions of selecting the channel, selecting the appropriate gain and offset value for the selected channel, converting the signal into digital format, communicating with the laptop PC, and saving the data to the Persistor (Peripheral Issue, Inc).



The Persistor is a 2 Mbyte flash PCMCIA card that stores the data. It also provides a simplified DOS environment. This provides a very easy avenue for data storage and system setup. Data files are simply stored as comma delimited files. Configuration files were stored in ASCII text file format.

Three layers of software were involved in this project. The first layer included that needed for channel selection, offset cancellation, gain selection, A/D conversion, data storage, and transmission functions. These were embedded in the Model 8 program which is written in C. The second layer covered the operational mode, real-time display, and operator interface program. This was written in Visual Basic running under Windows 95. Thirdly, the data processing software requirements which were met by using Excel.

The real-time viewing of the data was essential in order to help determine/verify proper sensor gains and offset. An automatic offset program was written to simplify the set-up. Other features of the developed software include the ability to view one or all of the real-time sensors, ability to change the vertical scale of each sensor, the ability to change the horizontal time scale for each sensor group, the ability to inject a user event mark for annotation, and the ability to change the sample rate and number of channels per experiment.

## Results

On October 21 through 23, 1997 gill net test were conducted at Coonamessett Farm. Present were research team members Ronald Smolowitz (Coonamessett Farm), Dave Wiley and Heather Rockwell (International Wildlife Coalition), John Kenney (NMFS), John Our (Cape Cod Gill Netters Association), Arnie Carr and Henry Milliken (Massachusetts Division Marine Fisheries), and Bruce Ambuter (Electronics/Data consultant).

The tests began using a new gill net section hung between a barn corner post and a tree located more than 150 feet away. Initially the measured lengths (eye to eye on load cells) were: float line = 145'10" and lead line = 147'2". After two pulls the measures were: float line 147'6" and lead line = 147'2". On 10/22/97 the net was rehung between two trees resulting in overall float line and lead line lengths of 189 feet each. The gill net for the first series of tests consisted of 6.5" mesh constructed of 14 gage twine; the float line was 5/16" polypropylene. The lead line was #65 Nova lead line. In reviewing these results the reader must keep in mind that all four corners of the net section were rigidly fixed. Catenary measurements indicate the horizontal displacement of the float line from its original position to the position it obtained at maximum applied loading.

The following is a test by test summary of the results. All tests that have file numbers beginning with 1021 and 1022 (actual month/day group) start out with the load cells zeroed under an unknown pretension. In most cases this tension was under 100 lbs in the float line and near zero in the lead line. Files beginning with 1023 start out with the load cells reading the actual pretension. Negative numbers indicate slack line.

The data recording system apparently saturated at loads exceeding 734 lbs. This fact was not discovered until after the tests were completed and the data under went final processing. For the purposes of the following discussion, where saturation was reached (734 lbs) the data was extrapolated by assuming approximately linear expansion.

### File # 10211204:

In this test the tractor was tied to the float line 25% down from the north end and a straight 90 degree pull was applied until the tractor load cell read 476 lbs. The maximum depth of the catenary formed at this load was 22.5 feet. The load of 476 pounds on the tractor line (TL) resulted in loads of approximately 900 pounds on the North float line (NFL) sensor and 800 pounds on the South float line (SFL) sensor. The corresponding lead line loads were 202 lbs (NLL) and 187 lbs (SLL). This test demonstrated that the load in an anchored net can greatly exceed an applied load at low force angles. A portion of the applied load was transmitted to the lead line by the net webbing. This load was distributed throughout the net section thus did not result in any meshes tearing.

File # 10220845

In this test a weak link made of 1/4" natural fiber manila line was spliced into the float rope at the center of the net section. The tractor was attached to the float line six feet north of the weak link position and the load applied at 0.8 mph. The manila weak link parted when the (TL) attained 600 lbs. The corresponding loads at this point were 388 lbs (NFL), 688 lbs (SFL), 248 lbs (NLL), and 193 lbs (SLL). The monofilament webbing tore at the point of failure after the float line parted.

File # 10220906:

This test was a replicate of the previous test, however, it must be kept in mind that some of the gill net webbing was now torn at the start of the test. The manila weak link parted when the (TL) attained 458 lbs. The corresponding loads at this point were 437 lbs (NFL), 550 lbs (SFL), 213 lbs (NLL), and 154 lbs (SLL).

File#10220926

This test was a replicate of the two previous tests but the load was applied at a higher speed; 8.2 vs 0.8 mph. The manila weak link parted when the (TL) attained 313 lbs. The corresponding loads at this point were 365 lbs (NFL), 355 lbs (SFL), 147 lbs (NLL), and 105 lbs (SLL). There was a 406 lb reading on the (SFL) just before breaking. The applied load was maintained after the float line failed and was taken up by the lead line. With a (TL) of 140 lbs, resulting in lead line loads just above 200 lbs, the monofilament mesh began to rip rapidly.

File #10220947

This test was similar to the previous slow speed tests except that the lead line was tied down near the point on the float line where the load was applied. This was to simulate the lead line being snagged on rocky bottom. The weak link (1/4" manila) did not break before the monofilament mesh began to rip. The webbing began to part when the (TL) attained 677 lbs. The corresponding loads at this point were 552 lbs (NFL), 635 lbs (SFL), 223 lbs (NLL), and 217 lbs (SLL). This would indicate that if the lead line is not free to move, i.e., snagged on the bottom, the webbing could be torn apart without the float line failing. The weak point in the float line would probably fail when all the webbing in that net section parted up to the bridles.

File #10221018

By this point in our testing the net webbing was badly torn. We used mending twine to connect the float line to the lead line at approximately six foot spacings in the vicinity of the applied load. We then repeated the first test; a weak link of 1/4" manila and a tractor speed of 0.8 mph. The manila weak link parted when the (TL) attained 638 lbs. The corresponding loads at this point were 596 lbs (NFL), 667 lbs (SFL), 298 lbs (NLL), and 292 lbs (SLL). It seems that with a stronger connection between the float line and the

lead line the lead line was able to take up more of the loading before the float line failed. This would imply that stronger mesh twine, or nets with up and down lines, would be able to take higher applied loads before the float line failed.

File # 10221040

This test was a replicate of the previous test. The 1/4" manila weak link used in these tests consisted of 8" of splice on each end and 26" of free line between splices. In this test the link failed when 2 strands of the line broke at the splice point and the third strand pulled free. The manila weak link parted when the (TL) attained approximately 750 lbs. The corresponding loads at this point were 601 lbs (NFL), 734 lbs (SFL), 356 lbs (NLL), and 358 lbs (SLL). This agrees with the hypothesis made from the results of the previous test.

File #10221115

The high observed loads in the previous test raised the question of the breaking strength of the manila line splices being used as weak links. To address this question we spliced the manila line into a section of float line and applied a straight tractor pull with load cells on each end. The line failed at 710 lbs with the break occurring in the free section of the link (not at splice). During this test the cables to the computer tangled and pulled out and tests were terminated for the day because of equipment failure.

Date: October 23, 1997

Location: Coonamessett Farm

Team members: Ron Smolowitz, Dave Wiley, John Our, Henry Milliken, Bruce Ambuter

File # 10230927

In this test we tested the webbing breaking strength by pulling a 48" diameter concave plastic disk through a section of webbing. This test was conducted on a net section about 15 feet away from the (NFL) and (NLL) load cells at very slow speed. The disk tore through the webbing when the (TL) attained 140 lbs. The corresponding loads at this point were 215 lbs (NFL), 81 lbs (SFL), 93 lbs (NLL), and 134 lbs (SLL).

File #10230938

In this test the load was applied at the center of the float line without a weak link and the angle of pull adjusted to observe changes in load at the four corners of the net section. We wanted to determine what would fail in the net system without a weak link present. The test terminated when the line pulled loose from the tractor load cell at a load probably in excess of 900 lbs (actual load unknown since we exceeded saturation).

File # 10230958

We attempted a repeat of the previous test but again the line failed at the attachment point to a load cell; this time the (NFL) at a load probably in excess of 900 lbs. These failures occur at knots in the 7/16" line used to connect the net to the load cells. These tests were conducted with vertical lines connecting the float line to the lead line.

File # 10231006

This repeat attempt resulted in a failure of the knot attachment to both the load cells in the south end of the net. The load probably exceeded 1000 lbs. The catenary at the time of failure was about 37 feet. We concluded we did not have the safe means to test an unmodified net to destruction. The whiplash occurring with each failure was having its toll on equipment.

File # 10231032

This was a test of a 1/4" manila link located seven feet from the (NFL) sensor. A load was applied at the net section center approximately 60 feet from the weak link at slow speed. As in the previous tests, the float line and lead line were attached by up and down lines every six feet near the applied load. The manila weak link parted when the (TL) attained approximately 900 lbs. The corresponding loads at this point were 733 lbs (NFL), 262 lbs (SFL), 570 lbs (NLL), and 688 lbs (SLL). The catenary at failure was 36 feet.

File #10231046

In this test one strand was cut on the float line near the net center. The load was applied at the center of the net section. The line parted at the bridle knot (attachment point to the NFL load cell) when the (TL) attained approximately 830 lbs. The corresponding loads at this point were approximately 800 lbs (NFL), 280 lbs (SFL), 478 lbs (NLL), and 611 lbs (SLL). The line did not fail at the cut strand.

File # 10231056

This was a replicate of the previous test with basically the same results; the line failing at the (NFL) load cell knot. The link (cut point) did not fail. The catenary at failure was 33'6". The failure occurred when the (TL) attained approximately 800 lbs. The corresponding loads at this point were approximately 900 lbs (NFL), 313 lbs (SFL), 524 lbs (NLL), and 674 lbs (SLL). The net section by this time was completely torn apart.

File # 10231136

A replacement net was hung consisting of new webbing 7.5" mesh X 14 gage and a used float line approximately 2 years old. A 1/4" manila link was placed in the float line 50' north from a load applied to the center of the float line. The link failed when the (TL) attained 740 lbs. The corresponding loads at this point were approximately 446 lbs (NFL), 255 lbs (SFL), 392 lbs (NLL), and 480 lbs (SLL). In this test net more load seems to be

distributed to the lead line when compared to similar tests on the previous net. The fact that the lead line (SLL) showed higher loading than the float line, where the load was being applied, is interesting (as in test 10231228). This may be due to the way the net was tied off or torn. This may indicate that a gill net can be hung in such a way as to transmit more load to the lead line, for example, by using different hanging ratios for the float line and lead line.

File # 10231228

This was a repeat of the previous test conditions but with a piece of 1/4" poly as the weak link. The link failed when the (TL) attained approximately 850 lbs. The corresponding loads at this point were approximately 458 lbs (NFL), 218 lbs (SFL), 414 lbs (NLL), and 719 lbs (SLL).

File # 10231302

In this test a fisherman's knot was tied in the float line in the net center 15 feet north of the applied load. The knot failed when the (TL) attained 411 lbs. The corresponding loads at this point were 366 lbs (NFL), 263 lbs (SFL), 78 lbs (NLL), and 116 lbs (SLL). The results of this test indicate that the used float line may be a lot weaker than new line of the same material.

File # 10231308

This was a repeat of the previous test. The knot failed when the (TL) attained 553 lbs. The corresponding loads at this point were 410 lbs (NFL), 322 lbs (SFL), 108 lbs (NLL), and 172 lbs (SLL). Similar to the previous test, the float line failed at the knot at lower than expected loads for that size line.

File # 10231333

A "Chinese finger" type connection was made on the float line in the same location the previous fisherman's knots were placed. This connection consisted of a piece of braided line, with core removed, placed over the ends of the float line and seized in place by two bands of light twine on each side. During this test the (TL) load cell malfunctioned and that load was not recorded. The recorded loads at failure were 383 lbs (NFL), 326 lbs (SFL), 186 lbs (NLL), and 159 lbs (SLL). The "Chinese finger" failed by the float line slipping from the braided line covering.

File # 10231403

In this test we spliced into the float line a flat plastic "Anderson" link, designed to fail at 250 lbs, into the float line 15 feet north of the applied load. The (TL) load cell was still inoperative so we used the (SLL) load cell in its place. The recorded loads at failure were 243 lbs (NFL), 97 lbs (SFL), 91 lbs (NLL), and 139 lbs (TL).

File # 10231411

In this test we tested the webbing breaking strength by pulling a 48" diameter concave plastic disk through a section of webbing as in test 10230927. The recorded loads when the disk broke through the mesh were 273 lbs (NFL), 129 lbs (SFL), 242 lbs (NLL), and 181 lbs (TL).

File # 10231415

In this test we spliced into the float line a flat plastic "Anderson" link, designed to fail at 450 lbs, into the float line 15 feet north of the applied load. The recorded loads at failure were 448 lbs (NFL), 165 lbs (SFL), 217 lbs (NLL), and 362 lbs (TL).

File # 10231421

This was a replicate of the fisherman's knot test. The recorded loads at failure were 404 lbs (NFL), 176 lbs (SFL), 398 lbs (NLL), and 490 lbs (TL).

File # 10231433

By this time in the testing the net was all torn apart and distorted. Three of the six load cells were malfunctioning due to banging around each time the net failed. This last test consisted of applying a load to the center of the float line at 8.2 mph. The recorded loads at failure were 438 lbs (NFL), 184 lbs (SFL), 405 lbs (NLL), and 488 lbs (TL). This test damaged two load cells beyond field repair putting an end to the experiment.

## Discussion

In spite of the long history of using gill nets, little is known on what happens when a large object encounters a net string. The large objects that most commonly encounter bottom sink gill nets in the New England groundfishery include otter trawl doors, scallop dredges, and whales. Whales may encounter gill nets frequently but may not make physical contact. Whale encounters with gill nets, that are known to result in entanglements, have not been observed to our knowledge and are extremely rare events when compared to mobile gear striking gill nets. The interaction of mobile gear and gill nets may shed some light on what transpires when a whale encounter occurs.

From experience, fishermen know that when a trawl door encounters a gill net string it commonly drags the string, sometimes for long distances, balling the gear up and/or breaking it apart. The gill net gear is commonly destroyed. On the other hand, when a scallop dredge encounters a gill net string the dredge commonly cuts right through the gear; float line, webbing, and lead line. After scallop dredge encounters the gill net fisherman can usually retrieve both remaining pieces of his gear as it is not often moved very far from where set. We can only speculate on the difference between these two types of encounters. A trawl door might snag the float line and webbing while a dredge might catch the lead line. Regarding whales, one can surmise that most encounters with the gill net gear do not result in an entanglement as whales are often observed swimming around gear without entanglement occurring. What portion of the encounters actually result in the whale striking the gear is unknown.

Since we know little about whale encounters with gear, and can not replicate these encounters using whales, we have to simulate to the best extent possible a situation where a large object comes into contact with a gill net. If the net can be modified in some manner to reduce the possibility of large objects snagging the gear, one can then postulate that whale entanglement risk would be reduced as well. In these tests the large object was designed to represent a whale calf.

Land testing of a gill net section is a poor substitute for at-sea testing of actual gill net strings. However, land testing is a very inexpensive means to get a preliminary understanding of what may occur with a particular net modification. While we did measure loads during the tests this again is not a substitute for laboratory testing of material breaking strengths. To accurately understand the forces working on the gill net section and weak links would require additional load cells and the measurement of angles to get complete force vectors. Experimental collection of these data would be extremely difficult because as load is applied the net changes shape in three dimensions. In addition, after each test the net is altered by stretching and tearing, so replication is not simple to accomplish. Trying to measure the speed of the impacting object, and the corresponding acceleration and torque, is beyond the scope of these low budget tests. All this being said,



this discussion will need to be kept in general terms with specific numbers only being used to show direction and tendencies.

In light of the above discussion, one of the first questions to arise in viewing the results is how valid are the loads observed at the point of failure of a weak link. Two tests (10231403 and 10231415) used calibrated links of 250 and 450 lbs breaking strength. These links, when placed in the float line between the applied load (TL) and the (NFL) load cell, failed when the (NFL) load cell indicated 243 and 448 lbs respectively. It would seem that in tests without up and down lines the float line load cell nearest the link gives a good indication of breaking strength.

Many of the tests were conducted using pieces of 1/4" manila line as the weak link. This size line should have a breaking strength around 600 lbs when new. Failures occurred at 688 lbs (10220845), 550 lbs (10220906), 667 lbs (10221018), 734 lbs (10221040), and 733 lbs (10231032) averaging 674 lbs for the five tests. In a straight pull (10221115) the 1/4" link failed at 710 lbs. In a high speed pull (10220926) the link failed at 406 lbs. In another test (10231136) the link failed when the nearby float line load cell read 446 lbs but the lead line in this test showed high loads as well. In all cases failures occurred close to the calculated breaking strength of this material.

The age and history of use of the line is an important consideration. Fishermen estimate that more than 80% of the gill nets in use may be older re-hung nets, that is, nets with new webbing but that reuse the old float and lead lines. Fishermen may be working with gear that is a lot weaker than they suspect. Fishermen use float lines, ranging in size from 5/16" to possibly as large as 7/16", made of polyolefins which should provide breaking strengths of 1,350 to 3,500 lbs. Since most of the nets in use are rehung and have been in operation for several years their breaking strengths might be considerably less. There is a need to take float line samples from the fishing fleet, test them to breaking, to get an understanding of what actual working strength is needed to safely haul gill nets.

The use of lower strength float lines in lieu of weak links is an option. Deterioration in strength due to the elements would likely require these lines to be replaced more frequently than larger diameter lines of the same material. On the other hand, gear with weaker float lines might be less likely carried away by draggers in gear conflict situations thus saving the gear and catch. Making the entire float line weak and biodegradable, for example, using manila would be a maintenance nightmare to a fisherman. Manila also becomes negatively buoyant as it soaks up water over time. However, this is an idea that may have some value.

The advantage of using a calibrated weak link in the float line is that its failure, if properly designed, would not be a function of float line strength/weakening over time. A properly designed link maintains its breaking strength while line deteriorates in strength

with age and use. Weak links would also be very obvious to enforcement. The weak links need to be designed so that they can resist torque loading, and they should not snag the webbing during setting. They should also be streamlined to offer no snagging opportunities to the whale.

It may be best to place the links within each gill net section as opposed to the bridle location. If two links were placed in each net, 75 feet in from each bridle, that would provide one link for every 150 feet of net string. An encountering whale would never be more than 75 feet from a link. Links at the bridle, instead of within the net, would double this distance. If links are to be placed at the upper bridles then the float line connection to the lead line would also have to be weakened.

These tests confirmed the previous test results that the webbing is not a very strong component of the gill net gear (10220947 and 10221018). A whale would probably go right through the mesh if the whale does not snag the float or lead line (10230927 and 10231411). It has also been demonstrated that the float line would break when a load is applied, before the webbing starts to tear, except in the situation where the lead line is holding fast to the bottom. This scenario would likely occur in rocky and boulder strewn substrates. With the float line parted, gill net webbing will tear apart with loads exceeding 140 lbs. However, the use of up and down lines can possibly add to the risk of entanglement by the added strength they provide to the gill net structure. In common practice, up and down lines are used to bag the webbing near the bottom to catch flatfish. This in effect lowers the profile of the gear in the water column which should reduce the risk of whales encountering the gear. However, once a whale physically makes contact with the gear, up and down lines could defeat the purposes of placing a weak link in the float line which would increase the risk of whale entanglement.

Any treatment that increase the bottom holding capacity of the gill net, or prevents the float line from moving (stretching in the direction of the applied force), would expedite a whale breaking through the float line and webbing and minimize catenary formation. Minimizing the displacement of the float line (low angles of displacement) increases the loading (reaction forces) in the float line relative to the applied load (force). Less elastic float lines might expedite a whale or trawl door breaking through the gear. Similarly, setting the gear under strain would help the gear resist displacement. The strain in the gear is a function of setting relative to the tidal current. In some areas fishermen deliberately set their gear without much strain or fish the gear in other than a straight set. Curved sets may increase the chance of whale entanglement from the standpoint of how a whale may behave to gear that, for example, partially surrounds the whales position (a horseshoe like set).

Knots are known to weaken a line. The line does not fail inside the knot but usually just before where the knot begins. In all likelihood this is due to the fact that the

fibers in the line can not function as designed; the fibers are prevented from moving freely and thus sharing the applied loading. The load cells were attached to the gill nets using lengths of 7/16" poly, looped and knotted. These knots failed at loads around 1000 lbs (10230938, 10230958, 10231006). We decided to test cutting and knotting the float line using a fishermen's knot; probably one of the strongest known methods of joining fine lines using a knot. These knots failed at 411 lbs (TL) and 366 lbs (NFL)(10231302); 553 lbs (TL) and 410 lbs (NFL)(10231308); and 490 lbs (TL) and 404 lbs (NFL)(10231421). The average of the float line loads at failure of the fishermen's knots was 393 lbs. The problem with using the float line itself as the weak link, either by knotting or cutting a strand, is that the breaking strength will be a function of the age and condition of the line.

### Instrumentation

The use of the prototype data logger suggested a number of improvements. Ideally it would be best to fabricate a printed board version of the logger. This would eliminate the reliability issues and hazards of using a hand-wired prototype. Several changes to the prototype that would improve flexibility include the ability to support multiple sensor excitation voltages, the ability to turn off the sensor excitation to reduce power consumption (allows for smaller batteries), the ability to save the sensor gain and configuration settings, the ability to support user axis labeling with an input section to support displays in actual sensor values, and the ability to easily change and resize the number of graphs on the screen. This latter ability might be attained by running multiple versions of the program with 1-4 screens.

The end result of the above suggested improvements to the prototype would be an integrated logger and software package where virtually all post data processing steps would be eliminated. The user would have more flexibility in reviewing the results in real time thus avoiding problems such as the load saturation we encountered. The software would support either both screen capture (which it does now) and direct integration into Excel or equivalent spreadsheet format. It is estimated that an integrated logger and software as described would cost about \$6,000 for the first unit (includes development cost of designing printed circuit and software) and \$3,000 for each additional unit.

## **Conclusion**

Previous tests by our group had established that if the float line of a bottom set gill net lost tension or the ability to transmit force (breaks), the line offers little resistance and consequently is less likely to snag and hold a moving object. This can be accomplished by reducing the floatation (buoyant force) and/or strength of the float line (for example, inserting a weak link).

The land testing performed in this project demonstrated that weak links placed in the float line will fail, when a force is applied, and will release tension on the float line. The link will only fail if the gear offers enough resistance to allow the breaking strength of the weak link to be exceeded. The resistance must come from the bottom holding characteristics of the lead line and anchors and the drag resistance of the webbing and float line in the water column. The lower the breaking strength of the weak link, the more likely the float line will part when hit by a large object. This would result in less risk of snagging the offending object and less damage to the gill net string.

One of the biggest unknowns in this whole problem is the question of the momentum of a whale and the resulting impulse related forces. If a whale hits a gill net, and the net offers resistance, the whale should generate enough force to break an appropriately designed weak link. However, if a whale just brushes up alongside a gill net, or a substantial catenary is formed prior to weak link failure, a weak link may not break before an entanglement occurs.

## **Recommendations**

1. Accurately survey the type of gill net gear in use including mesh size, twine size, float and lead line size, material, and age. Take known age samples of float line and test the breaking strength of these samples.
2. Test different net hauling procedures to develop ways to haul the gill nets with minimum loading on the float line.
3. Conduct in water tests, similar to the land testing of gill nets, but using longer strings. Develop photographic techniques for measuring net displacement.
4. Have fishermen fish nets with float line weak links to determine operational problems. We suggest low breaking strengths on the order of 500 lbs for starters.

**GILLNET RESEARCH & DEVELOPMENT**  
NMFS Gear Research Team  
May, 2001

In 1997, NMFS funded a study of gillnet modifications which consisted of land testing of weak links and the tension (loads) produced in the nets when they are pulled in various directions. This was followed by in situ measurements of loads necessary to drag actual gillnets across the ocean bottom. These studies in conjunction with the analysis of gillnet entanglements, led to a proposal to develop a "low strength float rope gillnet". This idea was discussed with various gillnetters who suggested that although most netters haul by both float and lead lines, it probably would be possible to haul solely with the lead line if it were strong enough. In 1998, ten experimental nets were built. Five of them were constructed with 1/8" twisted poly floatlines and five had 3/16" twisted poly floatlines. These were used by fishermen and fished along with their traditional gear. Testing was also done to determine how much load was necessary to part the floatline. This was done by setting the net and then pulling sideways on the floatline to simulate a whale swimming through the gear. The commercial tests of this modified gear were not successful, as the small diameter floatline kinked and dipped through the meshes so badly that the gear was soon unfishable. However, the tests did indicate that the nets could be set and hauled without parting the floatline.

In 1999, twenty experimental nets were built. Based on the feedback from the gillnetters who had tested the small diameter floatrope nets, it was decided to have ten nets built with typical floatlined and # 200 floats, with 1100 pound breakaways spliced in every eight fathoms along the floatline. These breakaways are simply smaller diameter line with an overhand knot tied in, that have been tested and fail at 1100 pounds. Field tests demonstrated that under most conditions the nets could be successfully fished and hauled.

In addition another 10 nets were built using an internal float type of line with breakaways also spliced in every eight fathoms. Use of the internal float (Mega) line has the advantage that it eliminates the external plastic floats traditionally used on the floatline. Disentanglement analysis has indicated that the external floats hinder the slipping of the floatrope if it is contacted by a whale, thus increasing the chance of entanglement. Feedback on the hauling and setting of these nets was very positive, however, some concerns were raised relative to the mega floatrope's ability to maintain the vertical fishing profile of the net. Another type of floatrope containing internal flotation has been identified and plans are being made to evaluate its performance in the future.

During the summer and fall of 2000, 60 experimental nets were built incorporating 600, 900 and 1100 pound weak links in the floatropes. Approximately 40 of these nets are in the field being evaluated while the remainder are scheduled to be used in gillnet anchoring tests.

## Mega- Float Gillnet Experiment

In July of 1999 ten gillnets were built incorporating a new type of floatline called Mega-float. This floatline built in Norway was 3 strand twisted poly line with a foam core in each strand. The Mega-float was an alternative to traditional gillnet floatlines which were poly line with a small football shaped floats tied every 6' on to the floatline. The thought behind the use of this Mega-float floatline was that it did away with the 50 football shaped floats on every net reducing the chance of line being hung up in the baleen. These nets were distributed to fisherman for testing from Portland, Me. to Hatteras, N.C. There were 2 main areas of concern with these net (1) will nets fish as well as traditional nets, (2) will the six 1100lb weak links we have spliced into the float line allow for fishermen to haul the gear successfully.

After approximately a year of field -testing feed back is quite mixed on the question of do the nets fish as well as traditional nets. The nets were given to 2 offshore gillnet vessels from Portland, Me. a 55' steel vessel and 44' fiberglass vessel both these vessels fish the deep water in the Gulf of Maine from Stouts Swell to Davis Swell. These fisherman found that the nets fished as well as traditional nets for the first few month and then began to catch more trash (crabs and skate). I can't be sure why the nets stopped fishing as well as traditional gear, it could be the foam was compressing in the floatline lowering it's buoyancy. I think more research into the foam used in the line is needed to determine just what was happening. I also think some underwater filming of the Mega-floatline fishing along side traditional gear would be helpful. These 2 Portland fisherman also complained that the twine was rolling up on the floatline. This twine rolling up on the floatline could have been caused by the floatline not having been properly stretched when hanging the nets or the result of the way the line is laid-up from the factory. There were no reported problems with the 1100lb weak links in the floatline.

One 55' fiberglass gillnet vessel from Portsmouth, N.H. which fishes the offshore GOM waters has been fishing 2 Mega-float nets for the last 12 months. This fisherman thinks the nets haul fine, set fine and catch as well as traditional gear. There have been no problems with the 1100lb weak links even on one trip where hauling was conducted in 50 knot winds and 17' seas. Last fall a gillnet fisherman from Gloucester tried the Mega-float nets for a few trips into the deep water in the GOM and reported problems with the twine rolling up on the floatline as similarly reported by the Portland fisherman. This Gloucester fisherman said that when the twine did not roll up gear fished as well as traditional gear with no problems with weak links.

A Chatham, Ma. gillnetter fishing a 42' fiberglass vessel has been testing the megafloat nets for several months in the area of the Great South Channel. This fisherman reports that nets don't fish as well in areas where there is a lot of tide but that on the inside bottom where there is less tide the nets fish comparable to traditional gear. There have been no reported problems with the weak links.

A North Carolina gillnet fisherman fished 2 traditional nets with floats and weak links in a string with 2 mega-float over the past winter and spring and is still using them as of 8-1-00 for Spanish Mackerel. The fisherman thought the mega-float nets fished as well as traditional nets but had problems with the float line stretching a bit making it a problem at times hauling and setting on a reel. Many of the N.C. gillnetters use a reel on the stern of the vessel to haul gear rather than a traditional Crosley netlifter as is seen on N.E. gillnet vessels. The fisherman thought that if the mega-float nets were hung with a bit more slack in the floatline this problem would be alleviated. There were no problems with any of the weak links.

We will continue to monitor these nets and work toward possible improvements in the construction of the nets and the mega-floatline.

### Weak Links in Gillnets Float Lines

In the Summer of 2000 (60) gillnets were built utilizing 3 different breaking strength weak links (600 lb., 900 lb., 1,100 lb.). Each net kept the same breaking strength link through out the net. Three different strength weak links constructed of rope of appropriate breaking strength (ROABS) were place equal distance apart along the float line. These nets have been deployed in the Great South Channel and throughout the Gulf of Maine for one complete fishing season (12 months) with less than a dozen failures reported out of the 180 weak links tested. Reports of failiures have been mostly when gear has been caught down on the bottom and lead line has already parted. Link failures have spanned all of the 3 sized weak links with the 600lb link registering over 75% of the failures.



### **Low Breaking Strength Line**

The NMFS Gear Research Team and the NMFS South East Region are currently contracting with cordage companies and polymer experts to develop a low breaking strength line to be used in the float line of sink gillnets. The challenge is develop a line with the same diameter, floatation and stretch ratios and currently used line but with a reduced breaking strength (600 lbs. >1,100 lbs.) Experimental line should be available for at sea testing in gillnets by Spring 2002.

9

Preliminary Report  
of  
Data Collected by Underwater Load Cells  
during  
Gillnet Experiments in the Bay of Fundy

February 2001

John F. Kenney  
NMFS Gear Research Team  
Kingston, RI

Underwater recording load cells were programmed and provided to East Coast Ecosystems for deployment by local gillnetters. Three bottom load cells were programmed, each to cover a two week period, for a total of approximately 6 weeks from July 17 through Aug. 25, 2000. A fourth unit, a surface load cell, was also supplied for gathering information of the loads exerted on buoy systems.

The surface load cell was inoperative for its entire deployment resulting in no data being collected relative to the forces exerted on the buoy systems. Data was collected by three vessels using a bottom load cell and is presented in the following 3 graphs\*. Information was recorded from 10 hauls. A haul conducted by the F/V LINDY DAWN on July 28<sup>th</sup> was not recorded due to a system malfunction. Of the 10 recorded hauls, the range of loads was from: 90 to 550 pounds.

An analysis of recorded loads needs to be conducted relative to the placement of the load cell in the gear and the direction from which gear was hauled. While the log sheets provided to the vessels were completed, additional information will be required to conduct further analysis.

It should be noted that these results are preliminary and that information from 10 hauls does not provide a very robust sample.

\* Graph file names: KC\_17-21P.JPG, LD\_24-27P.JPG, Aug7-11P.jpg

# Gillnet Load Testing FV Kiwi Cajun July 17 to 21, 2000

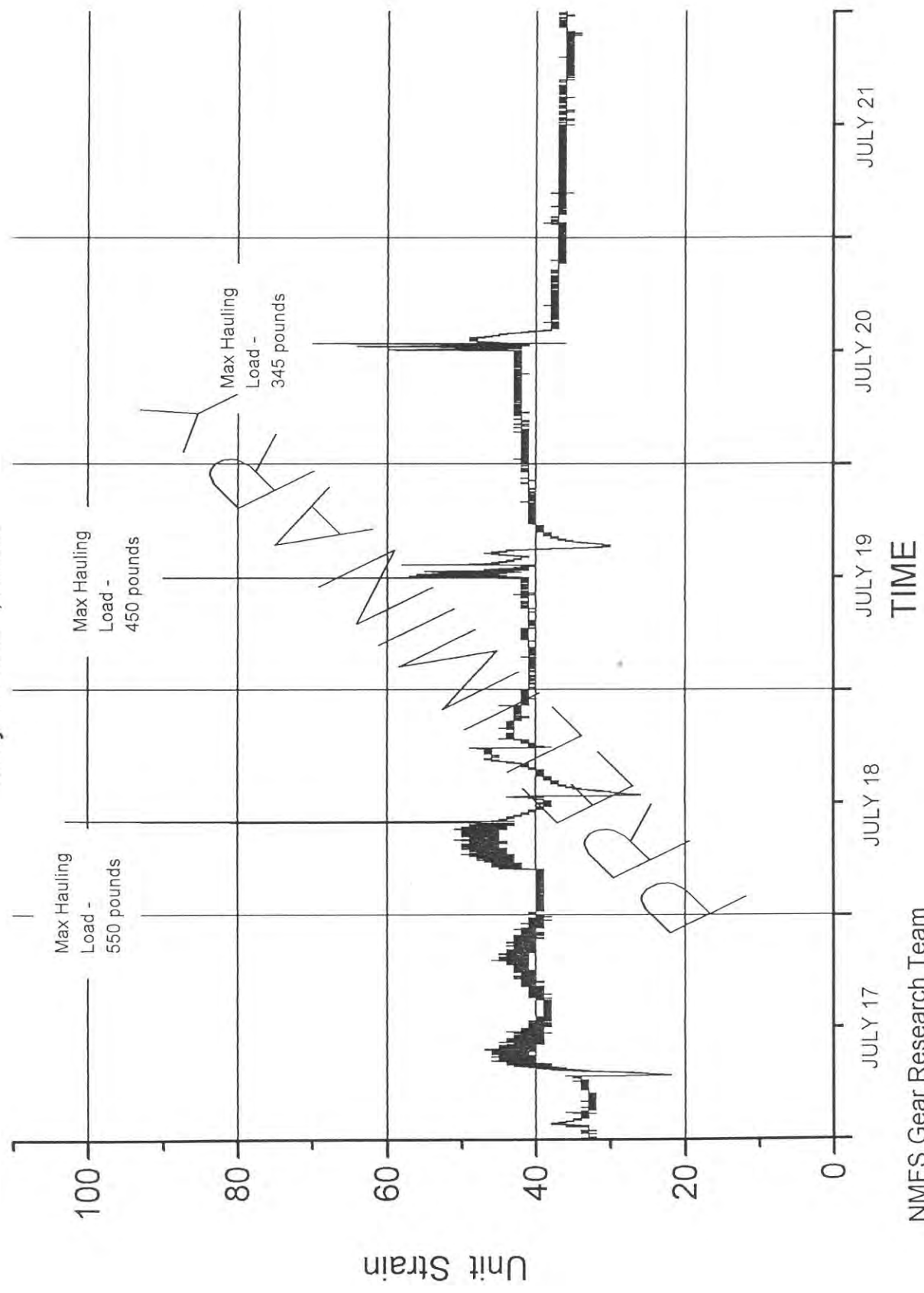

NMFS Gear Research Team  
Can\_1 unit 001 KC\_17-21P.JPG

Gillnet Load Testing  
FM Lindy Dawn  
July 24 to 28, 2000

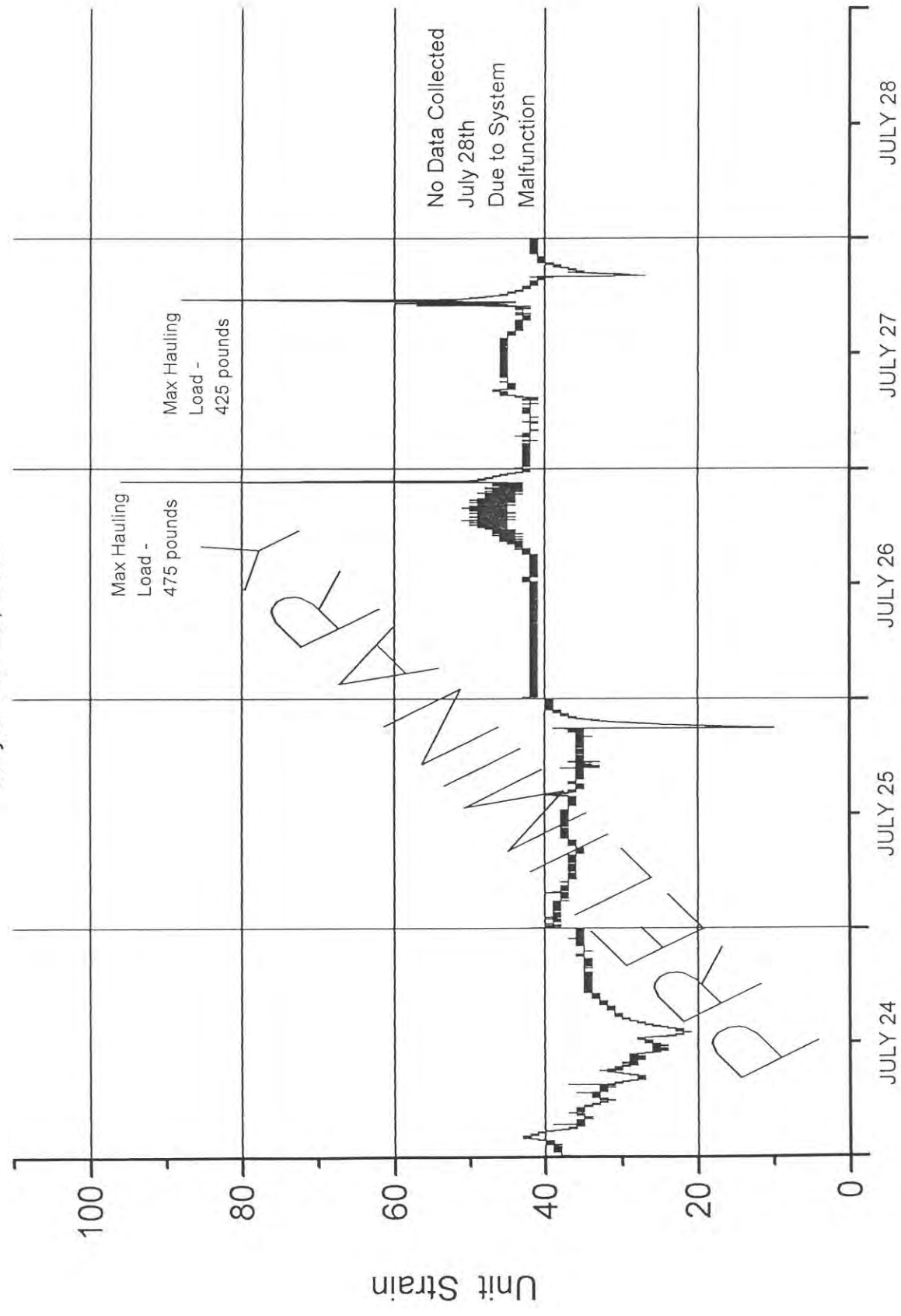

TIME

Gillnet Load Testing  
FM FUNDY TRAPPER  
Aug. 7 to 11, 2000

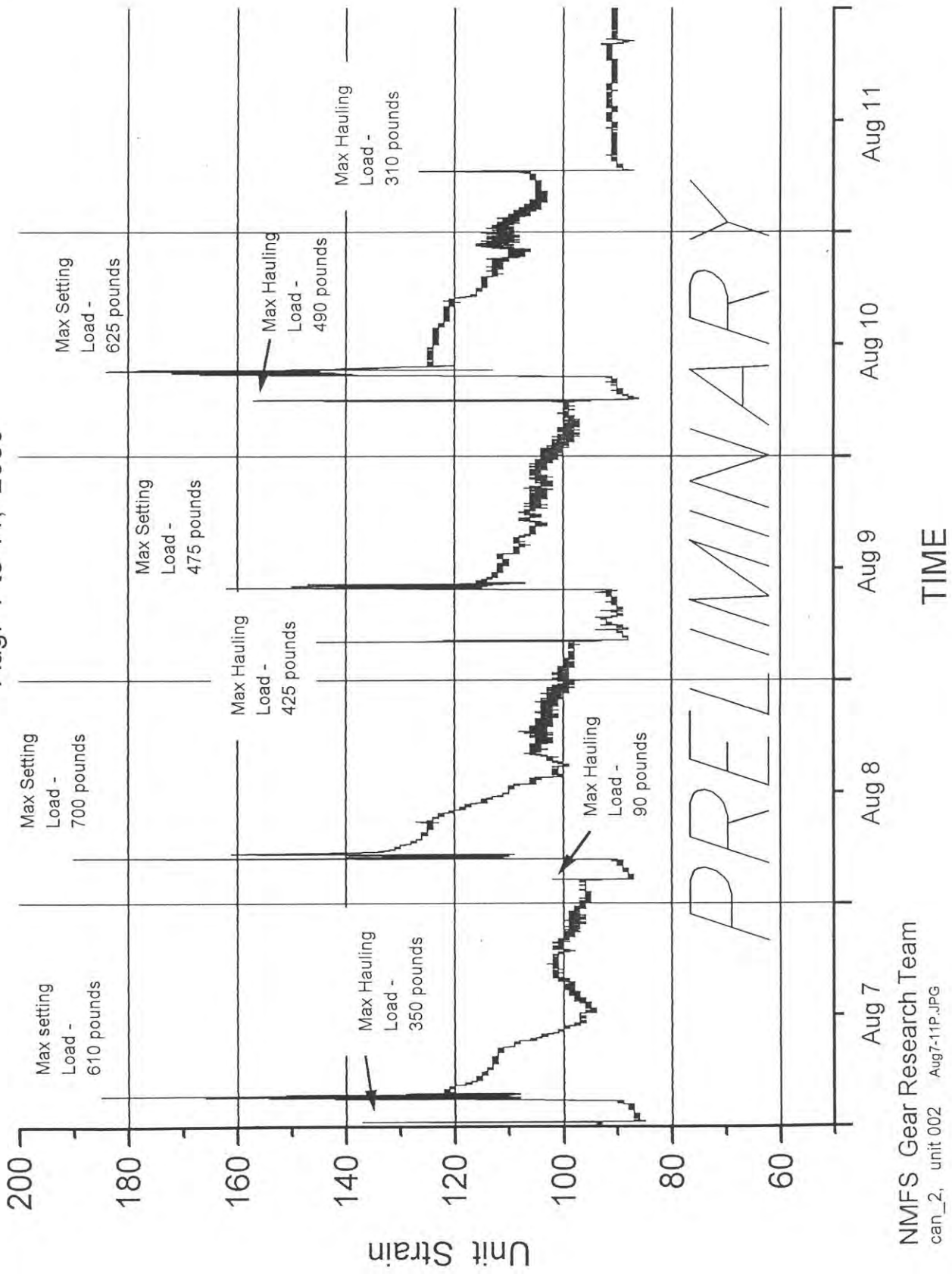

## Loads Measured in Lobster and Gillnet Gear

NMFS Gear Research Team  
February, 2002

### LOADS RECORDED IN GILLNET GEAR UNDER NORMAL FISHING OPERATIONS

Loads recorded in gillnet operations Downeast during 5 sets ranged from 190 to 655 pounds while hauling the gear. (Lc-02)

Loads recorded in commercial gillnet operations in the Bay of Fundy for 10 sets aboard three vessels ranged from 90 to 550 pounds hauling the gear and 475 to 700 while setting the gear. The gear was set in approximately 50 fathoms of water on hard bottom with 80 lb grapple and 85 lb kedge type anchors. (Can\_1)

### LOADS RECORDED IN VARIOUS LOCATIONS OF GILLNET GEAR WHILE THE GEAR IS BEING TOWED

Resistance of a 20 net un-anchored string set on mud/gravel on the edge of hard bottom - 1175 pounds towing gear length wise by its buoy line and 1435 pounds towing sideways from the center of the string. (Lc-39-08 D3)

Load measured in floatline between nets 5 & 6 was 690 pounds and 340 pounds for the above events. (Lc-39-09 D3)

Resistance of a 15 net string secured with 22# Danforth both ends - 1470 pounds towing the gear length wise with its buoy line (gear not moving) and 1055 pounds towing sideways from the center of the string (gear not moving). (Lc-39-09 D2)

Resistance of a 15 net string secured with 50# mushroom both ends - 600 lb @ 0.5 kts, 1000 lb @ 1.0 kts, and 1400 lb @ 1.4 kts. while towing the gear length wise with its buoy line and 700 lb at 0.5 kts and 850 lb at 1.0 kts towing sideways from the center of the string. (Lc-39-09 D1)

Load cell located between nets 7 & 8 in 15 net string secured w/22lb Danforth's. Tow rope tied into floatrope of net #7 between two 1100 # weak links. Load cell recorded 940 pounds as both weak links parted and peeled floatline away from webbing and the rest of the net. (Lc-41)

**LOADS MEASURED HAULING COMMERCIAL LOBSTER GEAR**

<u>DESCRIPTION OF GEAR</u>	<u>LOAD IN POUNDS</u>
48 trap trawl, 50" wire traps, 185 fm 24 fm between traps	2800
44 trap trawl, 50" wire traps, 120 fm 30 fm between traps	525 - 850
40 trap trawl, 48" wood traps, 181 fm 23 fm between traps	2050
40 trap trawl, 40" wire traps, 185 fm 20 fm between traps	The maximum reading of 2400 lb was exceeded
40 trap trawl, 48" wood traps, 36 fm 23 fm between traps	1700
40 trap trawl, wood 6 brick, 36 fm 23 fm between traps	1550
10 trap trawl, 52" wire traps, 40 fm	320 - 650
5 trap trawl, 48" wire traps, 10 fm	250 - 470
4 trap trawl, 48" wire traps, 45 fm 10 fm between traps	410 - 650
3 trap trawl, 48" wire traps, 33 fm 15 fm between traps	1160
3 trap trawl, 48" wire traps, 32 fm 8 fm between traps	580 - 600
3 trap trawl, 43" wire traps, 40 fm	325 - 340
3 trap trawl, 42" wire traps, 33 fm 15 fm between traps	825
3 trap trawl, 40" wire traps, 30 fm 15 fm between traps	775
2 trap trawl, 48" wire traps, 25 fm 15 fm between traps	580
Single, 48" wire trap, 8 fm	55 - 160

**TOWING LOBSTER TRAPS - 48" wire traps**

Single	1	kt	80
	6	kts	400
2 Traps	1	kt	140
	2	kts	230
	3	kts	325
Hung up on other gear			620

## Loads on Buoy Systems

NMFS Gear Research Team  
February, 2002

### OFFSHORE LOBSTER FISHERY

There were eight deployments in the offshore lobster fishery from March 2000 to July 2001. Six were successful in returning data while two were not (see table below). While a total of 310 days of data have been collected it should be noted that no extreme weather conditions were encountered during this period. The highest load recorded was 535 pounds with a buoy system consisting of two poly balls and a highflyer.

Number	Programed	Deployed	Area	Max Observed Load - Pounds
LCB-01	2/23 - 4/28	3/6 - 4/20	Gulf of Maine	370
LCB-02	4/12 - 5/26	4/17 - 5/21	Hydrographer Canyon	490
LCB-03	5/19 - 7/3	Unit & gear lost – No data recovered		--
LCB-04	10/18 - 12/2	10/26 - 12/2	Southern N.E.	360
LCB-05	11/28 - 1/27	12/2 - 1/23	Hydrographer Canyon	420
LCB-06	11/30 - 1/30	Unit flooded – No data recovered		--
LCB-08	4/24 - 8/1	5/4 - 7/25	Offshore	190
LCB-09	4/24 - 7/31	5/3 - 6/20	Hydrographer Canyon	535

### NEAR-SHORE LOBSTER & GILLNET FISHERY

Three Near-Shore deployments on buoy systems totaling 68 data-days were conducted in 2000 & 2001 in an area with high tidal currents.

LCB -Cutler	6/9 - 8/2	6/14 - 7/7	Near-Shore Downeast	125
LCB-07	4/3 - 6/7	4/16 - 5/27	Near-Shore Downeast	125
CanB_01	7/6	7/16 - 7/20	Near-Shore BOF	105



**TOWING BUOY SYSTEMS**

DESCRIPTION		Max Load - pounds	
Two 60" Scan floats & high flyer	180 fm warp	5.5 kts	550
	130 fm warp	5.5 kts	460
One 60" Scan float	120 fm warp	5 - 6 kts	465
One 60" scan float & high flyer	50 fm warp	5 kts	115
One 40" scan float & high flyer	50 fm warp	5 kts	95
One LD-40" scan float & high flyer	50 fm warp	5 kts	105
One 50" low drag Scan float with two 7" x 18" buoys	100 fm warp	2 kts.	150
		parted gear	640
One 40" Scan float with two 6" x 14" 100 fm warp		4 kts	280
		8 kts	400
		14 kts	430
9" x 16", 6" x 14" & 10" hard float 90 fm warp		5 kts	60
		8 kts	180
		10 kts	240
One 7" x 14" buoy on 14 fm warp		8 kts	80
		20 kts	120

## In Situ Observations of Lobster Gear

H. Arnold Carr  
Massachusetts Division of Marine Fisheries

**Introduction:** In situ observations of lobster gear was undertaken in waters located off the New England coast. Some of the gear is found in or adjacent to waters deemed critical habitat for endangered marine mammals such as the Right Whale. Attached to this summary is a cruise report and a video script of a 16 minute summary tape of these activities.

**Purpose:** To ascertain the in situ functional attributes of commercial lobster trawl gear so as to determine the potential to entangle marine mammals and to provide an understanding toward possible approaches to mitigate this potential. A lobster trawl is defined as a multiple set of traps attached in series by a single line.

This investigation is considered part of a primary response resulting from a series of meetings with NMFS and the commercial fishing community. The meetings discussed the potential for entanglement of Right Whales in commercial lobster and gillnet gear and avenues of possible mitigation. The gear is sometimes abundant in areas deemed critical habitat for this species. This investigation addresses the issue of how this fishing gear lies in situ; determining this will greatly assist in ascertaining the means to reduce entanglement of endangered marine mammals.

**Methods:** A team of biologists, gear technologists and commercial fishermen combined with remote operated vehicle (ROV) equipment gathered on commercial lobster vessels off the coast of Massachusetts and Maine. The team observed static commercial fishing gear set under commercial conditions. Commercial lobstermen voluntarily provided vessel support.

**Results:** The ROV was deployed at sea for four days. One day was spent in Massachusetts Bay and the other days off the Maine coast. All of the observations were made on lobster gear. In Massachusetts Bay multi-pot trawl (lines) were surveyed; the trawls consisted of more than 10 pots per trawl, but only 2-3 pots or traps were observed on each trawl because of the normal restriction of the ROV tether length. Off the Maine coast, single traps and the more common paired traps were observed as well as trawls of up to three traps. Paired trawls, a trawl with two traps, were the most common.

The trap lines, a line or combination of lines in series that attach the buoy to the bridle of the first trap, consisted of: a) sinking line held up off the bottom by a buoy (or toggle) attached on the line in the midwater column; or b) sinking line on the buoyed end of a buoy line and floating line on the trap or deep part of the buoy line. These result in the line having a vertical configuration near the water surface and just off the bridle of the trap nearest the buoy line. The buoy line did loop where the two lines met and the magnitude of the loop related to the scope and lengths of the respective lines. The vertical configuration of the line near the sea bottom is deemed important nearer the sea bottom in order to prevent the line from entangling on very rocky bottom.

One of the objectives of the survey was to view sinking and floating groundlines that connected the traps in a trawl. Observations in each dive proved that sinking line did what it was intended to do: it was usually right on the bottom, but in a few instances it was up to six inches above the substrate. Several makes of floating line were observed. In Massachusetts Bay, one trawl observed was set with a taut floating

groundline. The groundline, that was observed by the ROV, was consistently 10 feet off the seabottom. The attitude of the floating groundline may also relate to the way it was rigged to the buoy lines.

Two experiments were conducted with pair traps. The experiments involved different types of groundlines - some floating varieties and a sinking type - set between two traps in each experiment. The first experiment set the paired traps "loose" where the second trap in the trawl is pushed overboard just before being pulled by the groundline attached to the first trap. The maximum altitude (off the sea bottom) of each 10 fathom groundline (as measured by the ROV) was as follows:

Superhaul(sinking)	0 feet
Polysteel(floating)	6 feet
Orange poly(floating)	10 feet

The second experiment involved first setting the trawls "loose" and then setting them "tight". Tight is described where the second trap is pulled off the vessel by the first set trap in the trawl.

<u>Loosely Set</u>		<u>Tightly Set</u>	
Superhaul(sinking)	0 feet	Superhaul(sinking)	0 feet
Polysteel(floating)	12 feet	Polysteel(floating)	16 feet
Yellow poly(floating)	10 feet	Yellow poly(floating)	18 feet

The second set, which was more tautly made than the first set resulted in floating groundline altitudes higher than the "loose" set trawls. The observers speculate that this may be the result of a "rubber band" effect of the first trap pulling the second closer to it. Other variables may contribute, too. These would include depth, current speed and direction, and trap design and size. The "rubber band" phenomenon warrants further investigation and it should be done with paired trawls as well as 10-20 pot trawls.

Concerns:

- ▶ The loop of the line in a composite (consisting of floating and sinking lines) buoy line. This loop gives a larger exposed profile to the buoy line.
- ▶ Knots in the buoy line especially where the sinking and floating line connect
- ▶ Toggles or buoys placed on the buoy line within the water column
- ▶ Knots in the buoy line where the buoy is attached
- ▶ Knots in the groundline
- ▶ The method of attachment of the gangion or bridle
- ▶ Floating line and its off bottom configuration even when apparently set taut.

Note: These results are a product of cooperative research undertaken by a team of investigators from the Maine Department of Marine Resources, Massachusetts Division of Marine Fisheries and NMFS and Maine and Massachusetts commercial lobstermen.

30 January 1998

# Investigations of Natural Fiber Ropes

## Summary

J. F. Kenney and G. S. Salvador  
NMFS  
1999

This project was conducted to demonstrate how the strengths of two natural fiber ropes change over time when subjected to a salt water environment. Eighteen samples of 5/16 inch sisal rope and 18 samples of 5/16 inch cotton rope were submerged in approximately 15 feet of water near the mouth of the Piscataqua River in Kittery ME, in Jan. 1999. Between January & August, a sample of each was removed for testing at intervals between 2 weeks and 2 months. Samples were placed in a testing machine and loaded until failure occurred. Breaking strength for each sample was recorded and is shown in the following graph. After a 5 to 6 month exposure the strength of both ropes was approximately 50% of their original strength. The last samples taken after 8 months of exposure left the sisal with about 20% of its original strength, and the cotton with about 10% of its original strength.

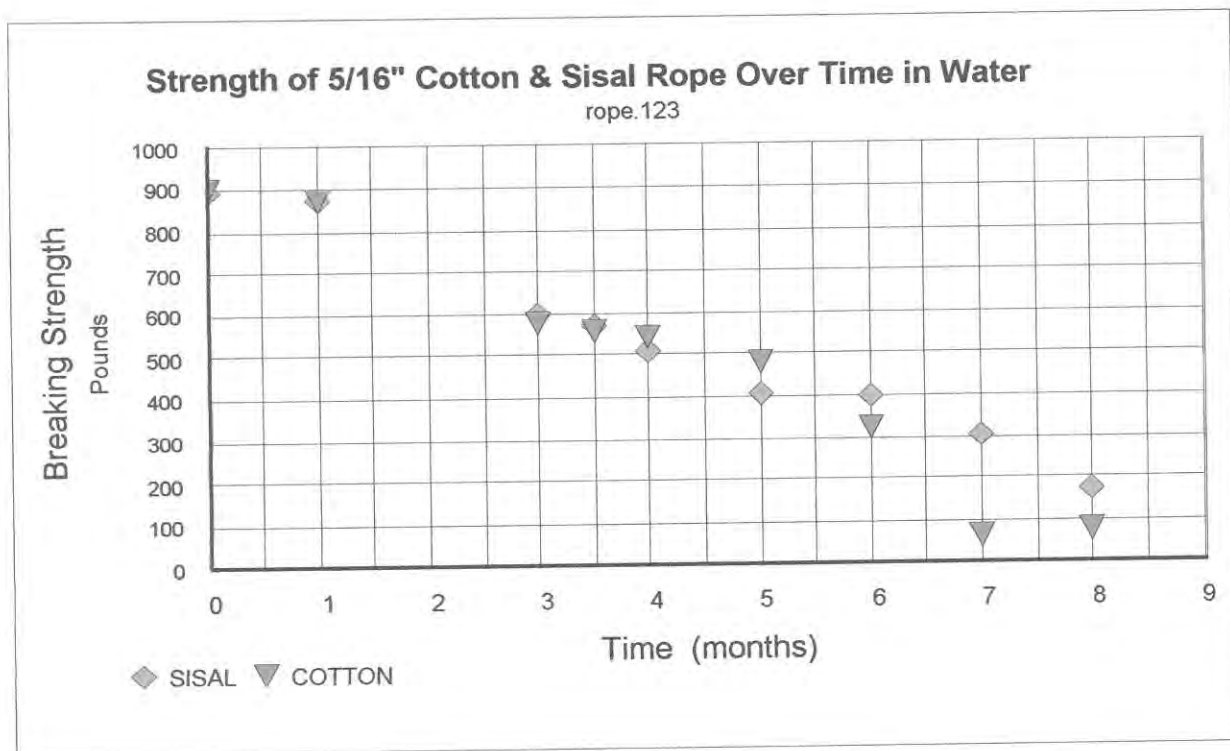

**Galvanic Timed Buoy Release Links Experiment**  
**NMFS Gear Research Team**  
**2000**

This experiment was designed to test the possibility of having buoys and buoy lines stored at the trap to reduce the need for vertical lines in the water column. Buoy lines were coiled up and fastened with galvanic links on the seabed to cement blocks. The experiment was monitored each day for 30 days and results were recorded.

	<u>Date set</u>	<u>Date proposed to surface</u>	<u>Date surfaced</u>
<b>#1 Experiment</b>			
1 Day link	7/26	7/27	7/27
2 Day link	7/26	7/28	7/28
3 Day link	7/26	7/29	7/29
4 Day link	7/26	7/30	7/29(1 day early)
5 Day link	7/26	7/31	7/30 (1 day early)
6 Day link	7/26	8/1	7/31 (1 day early)
7 Day link	7/26	8/2	7/31 (2 days early)
10 Day link	7/26	8/5	8/3 (2 days early)
14 Day link	7/26	8/9	8/11 (2 days late)
30 Day link	7/26	8/27	8/29 (2 days late)
<b>#2 Experiment</b>			
1 Day link	8/14	8/15	8/15 noon
2 Day link	8/14	8/16	8/16
3 Day link	8/14	8/17	8/16
4 Day link	8/14	8/18	8/17
5 Day link	8/14	8/19	8/17
6 Day link	8/14	8/20	8/18
7 Day link	8/14	8/21	8/18
10 Day link	8/14	8/24	8/21
14 Day link	8/14	8/28	8/26
30 Day link	8/14	9/13	9/16
<b>#3 Experiment</b>			
1 Day link	8/21	8/22	8/22 up at 5:30pm
2 Day link	8/21	8/23	8/22 (up at 6:00pm)
3 Day link	8/21	8/24	8/24 (11 hours early)
4 Day link	8/21	8/25	8/25 (on time)
5 Day link	8/21	8/26	8/26 (on time)
6 Day link	8/21	8/27	8/26 (1days early)
7 Day link	8/21	8/28	8/26 ( 2 days early)
10 Day link	8/21	8/31	8/28 (3 days early)
14 Day link	8/21	9/4	9/2 (2 days early)
30 Day link	8/21	9/20	9/17( 3 days early)

Comments: All buoys were set at 6pm and checked every day at 6pm.

	<u>Date set</u>	<u>Date proposed to surface</u>	<u>Date surfaced</u>
<b>#4 Experiment</b>			
1 Day link	8/22	8/23	8/23 (up 3:30 pm)
2 Day link	8/22	8/24	8/24 (on time)
3 Day link	8/24	8/27	8/27 (up in morning)
4 Day link	8/25	8/29	8/28 (1 day early)
5 Day link	8/26	8/31	8/31 (on time)
6 Day link	8/26	9/1	8/30 (2 days early)
7 Day link	8/26	9/2	9/2 (on time)
10 Day link	8/28	9/7	9/5 (2 days early)
14 Day link	9/2	9/16	9/15 (1 day early)
30 Day link	9/17	10/16	10/14 (2 days early)

**Comments:**

All tests were set at 5pm to re-check each evening after coming in from hauling. I can't see any real applicable use for these links. I don't believe these links holding buoys or balloons under water would begin to be strong enough to hold for expressed time given the early release times especially bringing tides and weather into equation.



**Galvanic time release link and associated hardware used in tests.**

of the transition section was related to the scope and lengths of the respective lines. The altitude off the bottom of floating groundline in a set of pair traps with a 10 fm groundline was measured as 3 fm.

## *Other Gear Research*

38. Investigations of Natural Fiber Rope Tests were conducted to demonstrate how the strengths of two natural fiber ropes (sisal & cotton) decreased over time when subjected to a sea water environment.

Develop Neutrally Buoyant Rope Conferred with rope makers to produce and acquire a small quantity of rope that is neutrally buoyant in sea water. In trying to move away from floating rope, fishermen felt this concept might address some of the short falls of sinking rope relative to hanging down and chafing. The rope was rigged in lobster pot trawls and video documentation obtained via SCUBA diver.

Neutrally Buoyant Pilot Project Purchased about 18 thousand pounds (62 miles) of neutrally buoyant rope from three manufacturers & distributed along the coast from Nova Scotia to Connecticut aboard almost 100 vessels in lobster & gill net fisheries. Feedback in general was positive with exception of the offshore lobster fishery where 2 of the 3 types of line exhibited unacceptable rates of deterioration and inshore fishermen east of Penobscot Bay noted problems with the rope chafing and getting hung down.

Large Scale Offshore Neutrally Buoyant Rope Project Supplied an offshore lobster vessel with enough neutrally buoyant rope to rig over all of their gear. Approximately 50 miles of rope weighing close to 30 thousand pounds.

39. Galvanic Time Release Buoy System In the Summer of 2000, three separate experiments utilizing galvanic time release (GTR) buoy systems were set up throughout the Gulf of Maine. Hard plastic floats were attached to cement blocks with ten different links with varying release times. Buoy systems were checked daily and results recorded. The GTR's failed to surface on the predicted dates more than 50% of the time.

Low Cost Acoustic Release Buoy System Contract to develop a low cost system - contractor released for breach of contract - no product developed or delivered.

Thwartable Link - Bottom Release Contract to develop a bottom weak link strong enough to hold the buoy & buoyline to the gear, but not strong enough to haul the gear until a command from the surface defeats the weak link. Contractor defaulted on contract - no product developed or delivered.

THE DESIGN, TESTING, AND PRODUCTION OF  
MECHANICAL WEAK LINKS FOR FISHING GEAR

FINAL REPORT

Peter M. Anderson  
Department of Materials Science and Engineering  
The Ohio State University  
2041 College Road  
Columbus, OH 43210-1179

April 29, 1998

**SUMMARY**

This report is the result of work under Requisition/Purchase Request No. 40EMNF700243 issued by the U.S. Dept. of Commerce, NOAA, NMFS in Gloucester, MA. This report summarizes the development and testing of two types of devices intended to reduce the probability of whale entrapment by fishing gear lines. The devices cause the line to separate into two sections when a sufficient tensile load is carried by the line. The first device, a **flat weak link** manufactured from high molecular weight polyethylene, was developed with an initial purpose of quantifying the working tensile loads carried by fishing gear lines during actual use. The second device, a **lap-joint weak link**, was manufactured using flexible, adhesive-lined, polyolefin tubing that shrinks to 1/3 the original diameter when heated. This link was developed to have minimal cross sectional area normal to the rope direction so that when the link is severed, the rope is able to slide more freely past the flipper, baleen, and other parts of the whale.

Approximately (300) 3" by 1.25" by 0.25" thick flat links (" denotes the unit of inches) were supplied which fail at 407 lbs if used as supplied, or fail at 258 lbs if a portion of the narrowed, gage section of the link is cut with a utility knife prior to use. Also, approximately (150) 3" by 1.25" by 0.50" thick flat links were supplied which fail at 865 lbs if used as supplied, or fail at 615 lbs if a portion of the gage section is cut prior to use.

Testing of the flat links reveals that the failure load increases by 15% if tested at 32°F and it decreases by 15% if the test temperature is 70°F. Testing of lap-joint weak links reveals that failure loads ranging from approximately 450 lbs to over 1200 lbs occurs, depending on the number of layers of tubing, the length of the lap joint, the test temperature, and the rope material, diameter, and condition (worn vs. new; wet vs dry). The 450 lb link is produced with a single-layer, 12" long section of tubing enclosing a 12" long lap between two ends of 5/16" diameter polydac rope. If a second 12" layer of tubing is applied over the first or, instead, a single-layer 24" long link is produced, the failure load approximately doubles. Adding more layers or length to the double-layer, 12" reference configuration produced only a modest increase in the room temperature failure load. The strength of this reference link at near-freezing temperatures was 45% larger than the strength at room temperature. Installation of the shrink tubing onto saturated wet rope or soaking of the link in salt water under 20 lbs tension for 1 week produced approximately a 20% reduction in room temperature failure load of the



reference configuration. Detailed test results of both the flat and lap-joint links are provided to help evaluate suitability for use as a weak link to mitigate whale entrapment by fishing gear.

### FLAT WEAK LINKS

#### Design

The dimensions of the flat weak links are shown in Figure 1. High molecular weight polyethylene manufactured as HMWPE-Pipe Grade by PolyHi Solidur was chosen since the material is used to construct water supply pipes for municipal water supply systems and is very resistant to degradation or leaching in water environments. The material also contains UV stabilizers to suppress degradation when exposed to the sun for extended periods. Testing revealed that the ultimate tensile strength of the material, averaged between room temperature and freezing conditions, is 4,250 lbs/in<sup>2</sup>. Desired failure loads of 250, 400, 500, and 800 lbs were identified, with the ultimate goal that these flat links would be used in field trials to determine the working line loads experienced during actual gear use. Flat links with 0.25" thickness were designed to fail at 400 lbs if machined to the dimensions specified in Figure 1, and fail at 250 lbs if the sections marked with an "x" in Figure 1 were cut prior to use. Failure loads of 800 lbs and 500 lbs were designed to be achieved if the thickness of the link were increased to 0.5", and the sections "x" were left uncut or cut, respectively.

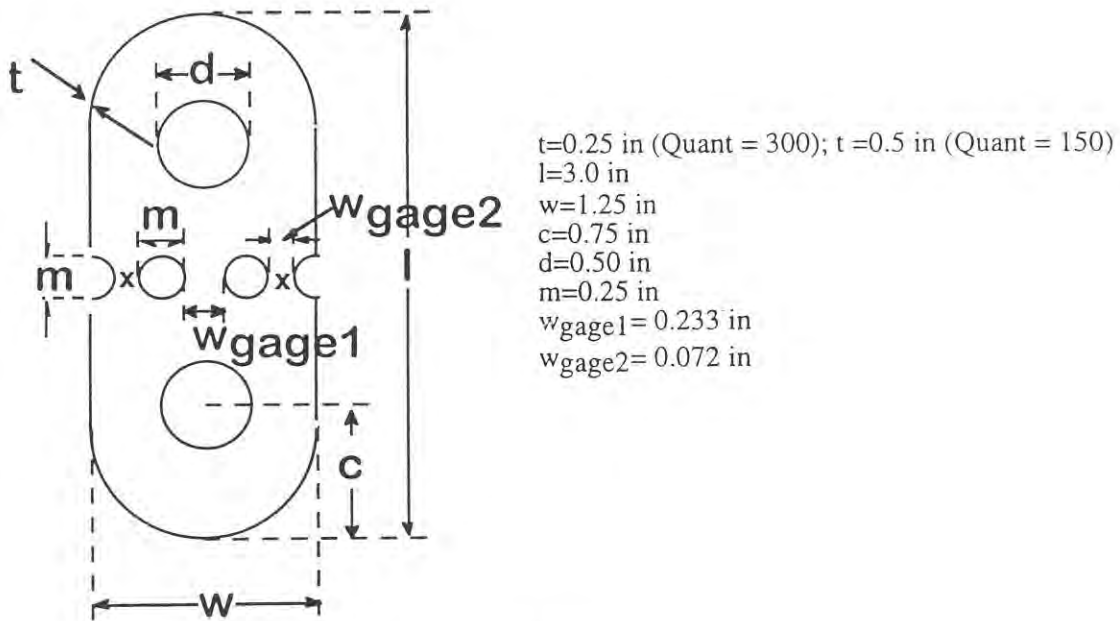

Figure 1: Dimensions of the flat weak links.

#### Manufacture of Flat Links

Approximately (300) 0.25" thick and (150) 0.50" thick flat weak links were manufactured using a computer-aided mill with programmed dimensions. The material machines easily so that less than one minute of actual milling is needed per link, once the set up is

configured. Approximate material cost per link ranges from 10 to 20 cents, depending on the thickness of the link, and the labor cost varies depending on the method of production.

### Testing of Flat Links

Samples were tested in tension in an Instron Model 1322 test frame with an Interlocken model 3200 controller. The specimen geometries and measurements of peak load to failure are shown in Figure 2 for both 0.25" and 0.50" thick flat links in uncut and cut configurations, and at room temperature and ice-water temperature. The results show that the 0.25" thick flat link has failure loads of 407 lbs in the uncut configuration and 258 lbs in the cut configuration, and the 0.50" thick flat link fails at 865 lbs in the uncut configuration and 615 lbs in the cut configuration. These failure loads are 10 to 16% larger if tested at ice water temperature and are 10 to 16% lower if tested at room temperature. This temperature-dependent strength is typical of most polymeric materials.



0.25" UNCUT

Ice water: 462lbs (pins)  
Room temp: 352lbs (rope)  
**AVERAGE: 407lbs±14%**

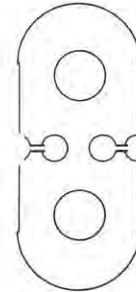

0.25" CUT

Ice water: 298lbs (pins)  
Room temp: 217lbs (rope)  
**AVERAGE: 258lbs±16%**

0.50" UNCUT

Ice water: 978lbs (pins)  
Room temp: 752lbs (rope)  
**AVERAGE: 865lbs±13%**

0.50" CUT

Ice water: 674lbs (pins)  
Room temp: 558lbs (pins)  
Room temp: 556lbs (pins)  
**AVERAGE: 616lbs±10%**

Figure 2: Peak loads for failure of flat links, for 0.25" and 0.50" thick links, tested in both uncut and cut configurations, at room temperature (70°F) and ice water (32°F) temperatures.

The actual failure loads are larger than the target design loads. The 0.25" thick links fail at loads within 4% of the target design values of 400/250 lbs while the 0.50" thick links fail at loads that are 23%/8% larger than the target loads of 500/800 lbs, respectively.

Figure 2 also shows that a second test of a randomly selected, cut, 0.50" thick flat link at room temperature produced a failure load that is less than 1% different than in the first test. This small change in failure load is indicative of accurate machining of the gage section dimensions and uniform material properties from one link to another.

A test type denoted in Figure 2 by "pins" indicates that links were loaded by inserting 0.5" diameter steel pins through the holes at each end of the link and displacing the steel pins apart from one another along the axis of the link, at a rate of 0.050 in/s, as depicted in Figure 3. A test type denoted by "rope" indicates that an end of rope was inserted through each hole at the ends of the link and knotted. The remaining free ends of the rope were gripped at approximately 6" from the holes and displaced at 0.050in/s. Samples loaded in the "pin" mode typically took 2s to fail while those loaded in the "rope" mode typically took as long as 30s to fail, due to the gradual tightening and extension of the knots and ropes involved.

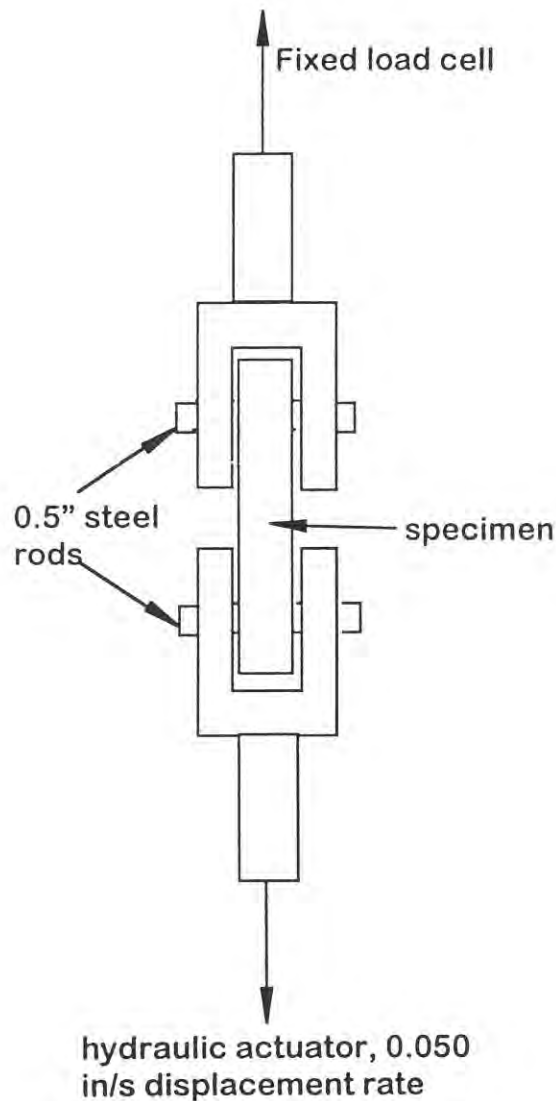

Figure 3: Specimen loading geometry for the "pin" case.

A Sensotec Model 41 load cell with an accuracy of  $\pm 0.1$  lbf was used to measure load. The overall accuracy of the peak loads reported in Figure 2 are  $\pm 15$  lbf for pin type tests

and  $\pm 1$  lbf for rope type tests, since a data acquisition rate of 5 points/s was used on most tests, and the actual peak may have occurred in between data acquisition events.

The measured load-displacement traces for the flat link tests are shown in Figure 4. The traces for the pin configurations reveal that the weak links reach peak strength at an elongation of 0.1" or less. Due to the ductile nature of the polymer used, final separation of the link required additional elongation beyond the peak load and, in all cases, the link separated into two pieces at less than 0.3" elongation. The substantially larger elongation to failure for the "rope" tests is due to the additional stretching contributed by the attached pieces of rope and knots. The tested "rope" samples show little evidence of any distortion of the hole, and indicate that failure occurs by separation at the gage section rather than pullout of the rope from a hole.

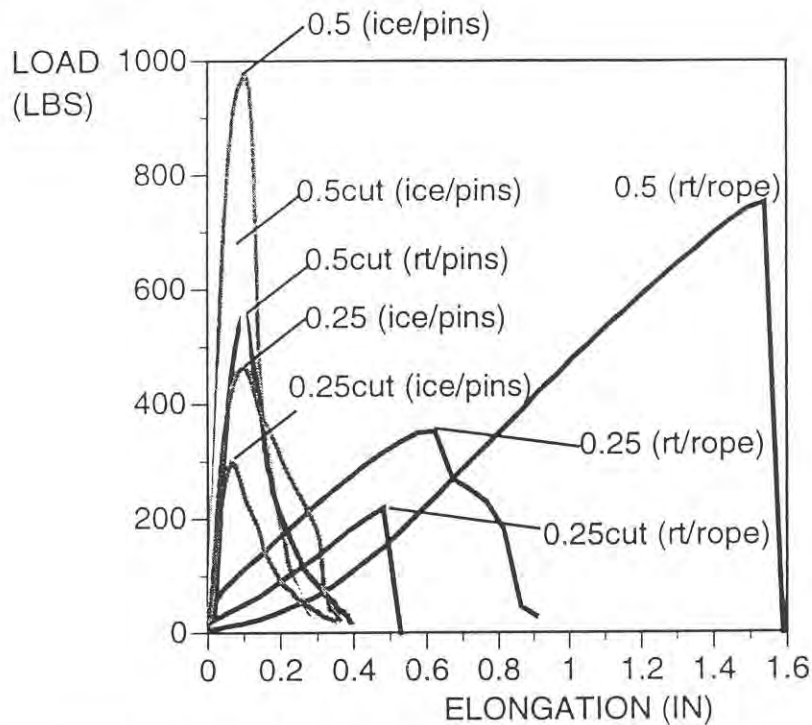

Figure 4: Load displacement traces for the flat links. The notation indicates the thickness of the link, whether the sections "x" of the link as depicted in Figure 1 were cut prior to testing, whether the test was at room temperature (rt) or ice water temperature (ice), and whether the loading geometry used pins (pins) or rope (rope).

### SHRINK-TUBING WEAK LINKS

#### Background

Discussions with the New England Aquarium revealed that the cross sectional area of a weak link may be important, since links with a smaller cross sectional area are more likely to be able to pass through the baleen of a whale. Discussions with the NMFS Marine Fisheries Group in Kingston, RI indicated that a link which did not require knots for attachment to the rope would be a further improvement. Although several ideas were

discussed, the concept of collapsing heat-shrink tubing, either of plastic or metal, around a rope emerged as a substitute for a knot. A flexible adhesive-lined polyolefin tubing sold by RayChem as series DWP-125-3/4 was identified. The product has an initial inside diameter of 0.75" but when heated to 80°C, it begins to shrink and when heated to above 125°C, the inside diameter shrinks to a final dimension of 0.23in. The technical information cites a final, after-heated wall thickness of 0.080", but can be less if the rope used has a diameter larger than 0.23in. An adhesive on the inner wall of the tubing becomes viscous during the heating process and flows easily to ensure a good bond between the tubing and the rope inside the tubing. A heat-shrink metal counterpart called "shape memory alloy" proved to be impractical since the diameter this metal tubing shrinks by 5% or less during heating.

### Configurations of the Shrink Tubing Weak Links

#### *Butt-Joint Geometry*

Two configurations were identified for initial testing. The first used a 12" long section of DWP-125-3/4 shrink tubing to cover a butt type joint between two lengths of 5/16" diameter polypropylene rope. The tubing was installed using a propane torch for the heat source. A second layer of shrink tubing was then installed over the first layer to form a 2-layer butt-type link. The link failed at approximately 100 lbs tension. The geometry was eliminated from further consideration, due to the insufficient tensile strength.

#### *Lap-Joint Geometry*

The second configuration used a 12" long section of DWP-125-3/4 to cover a lap joint, with the two ends of the rope overlapped by 12in, as depicted in Figure 5. The lap joint sustained over 400 lbs prior to failing. In order to evaluate the lap joint link further, a test matrix shown in Table I was devised, and the links were manufactured and tested in tension. The reference test, identified as TEST 0, calibrated a 12" double-layer lap joint,

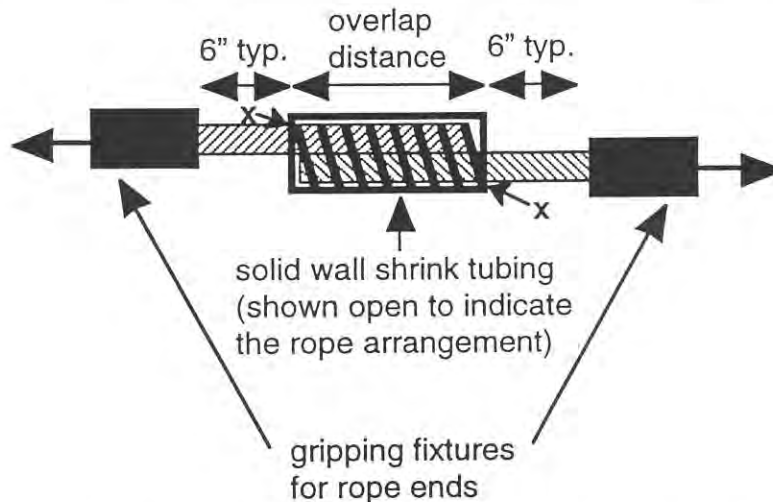

Figure 5: A lap joint using shrink tubing and the gripping geometry for tensile testing. The points x mark the typical failure initiation sites for debonding of the rope from the adhesive.

Table I: Test Matrix for Shrink Tubing Lap-Joint Weak Links

Test	Diam.	Lap	#Layer	Temp	Install	Hold	Purpose of test	Failure load(lbs)
0	5/16in	12in	2	room	dry	none	Standard reference test	845
1	5/16	12	2	room	dry	none	Consistency of load	894
2A	5/16	18	2	room	dry	none	Vary overlap	886
2B	5/16	24	2	room	dry	none	" "	1031
3A	5/16	12	3	room	dry	none	Vary # layers	886
3B	5/16	12	4	room	dry	none	" "	921
3C	5/16	12	1	room	dry	none	" "	445
4	5/16	24	1	room	dry	none	Incr. overlap/decr. # layer	972
5	5/16	12	2	ice	dry	none	Vary test temp.	1176*
6	5/16	12	2	room	wet	none	install on wet rope	706
7	5/16	12	2	room	dry	1 week	Effect of hold in salt water	690
8	7/16**	12	2	room	dry	none	Incr. rope diameter	1219
9	5/16‡	12	2	room	dry	none	Chg. to polyprop. rope	668

Notes: \*The rope failed at the grips prior to the failure of the link.  
 \*\* 7/16" diameter white rag rope with polydac tracers was used.  
 ‡5/16" diameter used green polypropylene rope was used.

formed by shrinking a 12" section of tubing over 12" of overlapping ends of rope, and then shrinking a second 12" long layer of tubing over the first. The test was conducted by gripping each end of rope as shown in Figure 5 and applying a uniform extension rate of 0.1 in/s. This "reference" joint sustained 845 lbs in tension before failing. The remaining series of 9 tests examine various aspects of the shrink tubing lap joint design, as indicated in the "Comment" column of Table I. All links tested were gripped along the rope extending from the link, and the same uniform extension rate of 0.1 in/s was used for all tests. All tests except TEST 8 and TEST 9 used 5/16" diameter black and white polydac rope as shown in Figure 7.

### Tensile Response and Failure Mechanism in Lap Joints

Figure 6 shows the traces of load versus elongation of the reference lap joint (TEST 0) and the attached rope. The sample has a relatively linear increase in load with extension. During this linear portion, the two sections of rope in the lap joint slide stably past one another. The peak occurs when the adhesive bond between the tubing and the rope fails, typically at the locations marked "x" in Figure 5. The behavior following the peak is to catastrophically drop in load, typically to 300 lbs or less, and fluctuate by  $\pm 10\%$  in load as the debonding of the adhesive-rope interface propagates along the lap joint. The result is that the shrink tubing deforms in an "accordion-type" of deformation as shown in Figure 7. The reference TEST 0 shows that the load smoothly decays to zero as the final sections of the rope are pulled out of the accordion section of the lap joint.

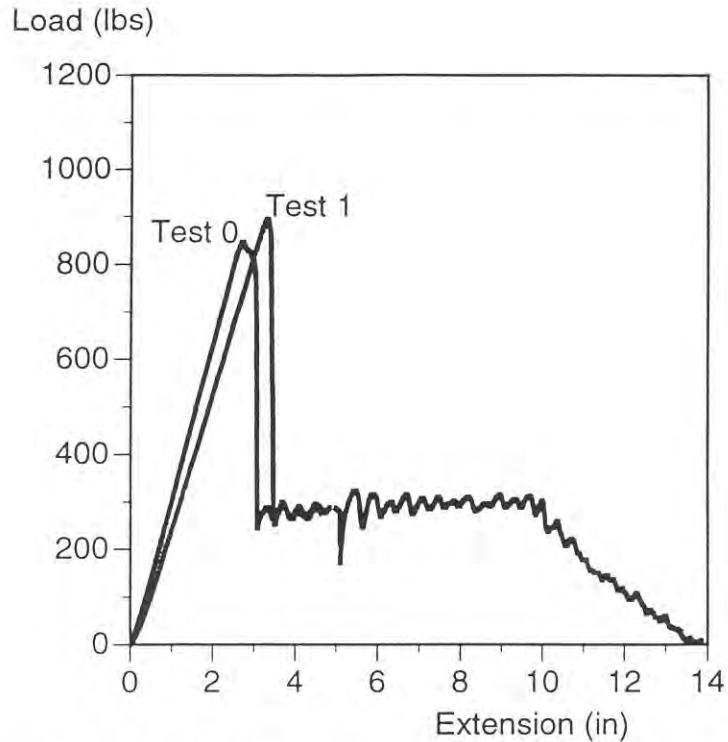

Figure 6: Comparison of the load versus displacement traces for TEST 0 (the Reference case) and TEST 1. Both tests are dry, room temperature tests of double-layer, 12" lap joints constructed from dry 5/16" diameter black and white polydac rope.

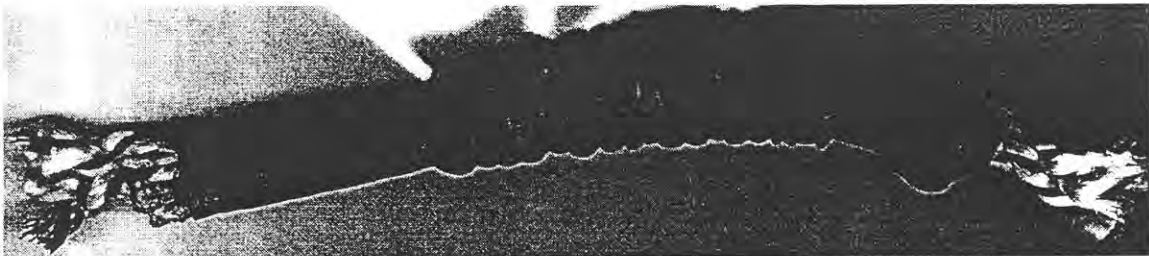

Figure 7: Accordion-type deformation typically observed in the deformation stages following the peak load. This sample is from TEST 7 and is shown at 75% of actual size.

**Consistency of Performance of Lap Joints**

Comparison of the failure loads for TESTS 0 and 1 in Table I reveal that the average failure load for a double-layer, 12" lap joint at room temperature is 870 lbs. The variation between TESTS 0 and 1 is only  $\pm 3\%$ . However, additional testing among a larger number of samples is required to determine the statistical performance.

**Effect Overlap Distance in Lap Joints**

Comparison of the failure loads for TESTS 0 and 2A in Table I reveal that for double-layer joints, increasing the overlap distance by 50% has no significant effect on the

failure load. A comparison of TESTS 0 and 2B show that even a 100% increase in overlap distance increases the failure load by 10%. The results indicate that additional overlap distance does not significantly increase the failure load for the double-layer, 12" reference link used here. However, comparison of the failure loads for TESTS 3C and 4 indicate that for these single-layer cases, an increase in the overlap dimension from 12" to 24" can double the failure load, from 445 lbs to 972 lbs.

The traces in Figure 8 show that the linear increase in load with extension, followed by the sharp decrease and an accordion-type mode occur even when the overlap distance is increased. The longer the overlap distance, the larger the amount of total extension in this accordion mode before the link is physically severed.

In summary, increasing the overlap from 12" to 24" appears to approximately double the failure load of single-layer joints, but produce less than a 10% increase for double-layer joints.

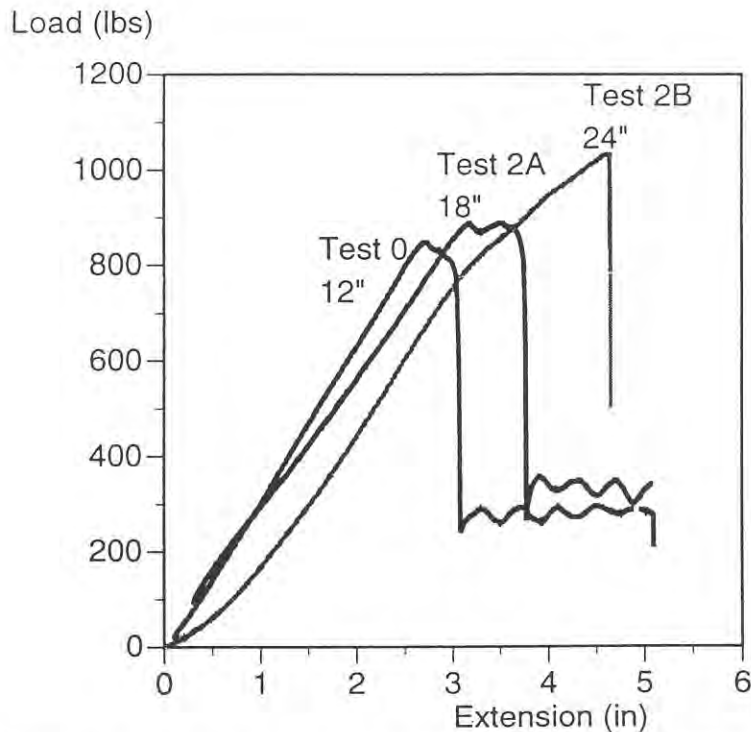

Figure 8: Load versus extension traces for double-layer lap joints with 12, 18, and 24" overlap.

#### Effect of Number of Layers of Shrink Tubing in Lap Joints

Comparison of the failure loads for TESTS 0 and 3A, 3B, and 3C in Table I reveals that increasing the number of layers from one to two in a 12" overlap joint nearly doubles the failure load, from 445 lbs to 845 lbs. An increase to three or four layers appears to increase the failure load by less than 10%.



The corresponding traces in Figure 9 show that the linear increase in load with extension, followed by the sharp decrease and an accordion-type mode occur even when the number of layers is increased.

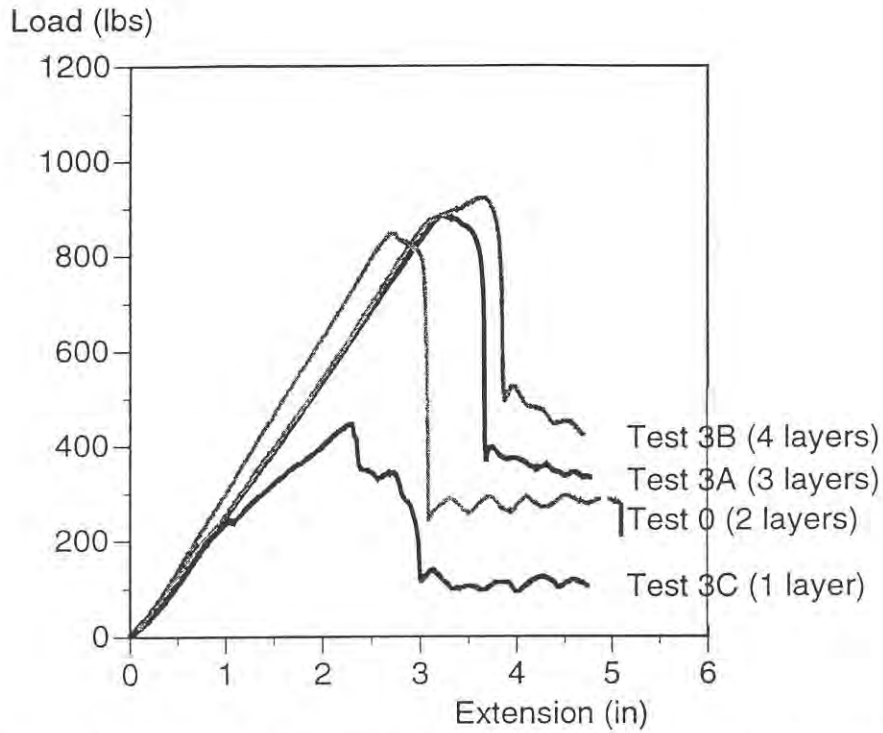

Figure 9: Load versus extension traces for a 12" overlap joint using 1, 2, 3, and 4 layers of shrink tubing.

#### Increased Overlap versus Increased Number of Layers in Lap Joints

Comparison of the failure loads for TESTS 0 and 4 in Table I reveals that a single-layer, 24" overlap joint has approximately a 15% larger failure load than the double layer, 12" overlap reference case. The corresponding load-displacement traces in Figure 10 show that the single-layer 24" overlap joint requires a smaller load to deform the joint in the subsequent accordion mode than in the reference case. Overall, the largest failure load obtained with 24" of shrink tubing is with a single-layer, 24" link rather than a double-layer, 12" link.

#### Effect of Test Temperature on Strength of Lap Joints

Comparison of TEST 5 and TEST 0 in Table I reveals that the failure load of a double-layer, 12" overlap joint increases by *at least 40%* when tested at ice-water temperature versus room temperature. The qualification *at least* must be used since the rope failed at the gripping points during the test at ice-water temperature. The large difference in failure load is attributed to a large dependence of the stiffness and strength of the polyolefin material and adhesive on temperature. The particular traces for each are shown in Figure 11.

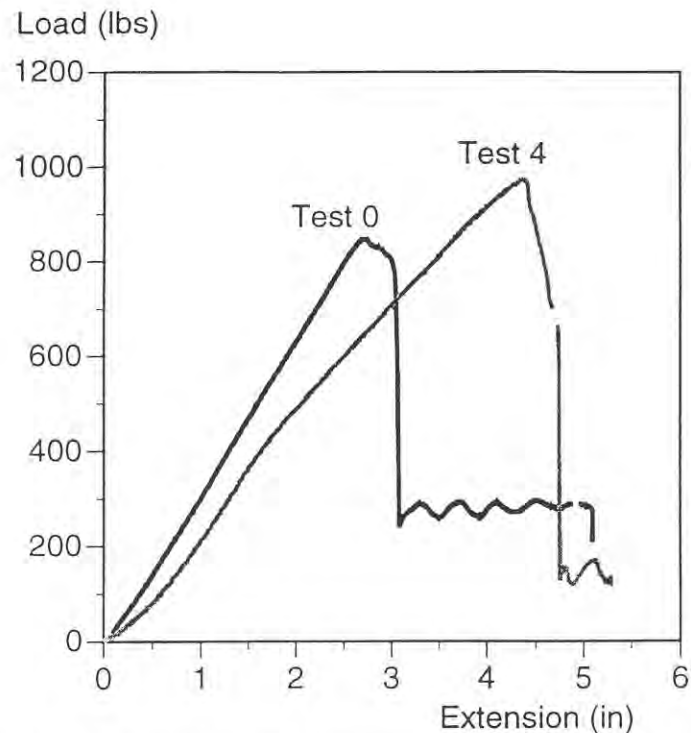

Figure 10: The load-displacement traces of a single-layer 24" overlap link (TEST 4) and the reference double-layer 12" overlap link (TEST 0).

#### Effect of Lap Joint Manufacture with Wet Rope

The sample for TEST 6 was fabricated in an identical manner to the reference sample, except that the rope was immersed in tap water for several minutes prior to installing the heat shrink tubing. The process of shrinking the tubing onto the wet rope actually extruded water from the rope. During the test, water extruded from the sections of the rope extending from the link out to the gripping points. The failure loads reported in Table I indicate that the wet installation produced a 16% reduction in failure load, compared to the reference test. Figure 11 shows that the stiffness (or slope) for TEST 6 also is less than that for the reference case. The response is consistent with a reduced coefficient of friction between the overlapping sections of rope in the joint.

#### Effect of Salt Water Exposure Prior to Testing

The sample for TEST 7 was fabricated in an identical manner to the reference sample. However, prior to testing, the sample was shipped to the NMFS Fisheries Engineering Group in Kingston, RI, where it was submersed in a salt water tank and loaded in 20 lbs tension for approximately 1 week. After removal from the tank, the sample was tested at room temperature and during testing, salt water extruded from the rope. The failure load is approximately 18% less than that for the reference case. Figure 11 indicates that the mechanical response is similar to the link manufactured with wet rope, including the accordion mode that leads to final separation.

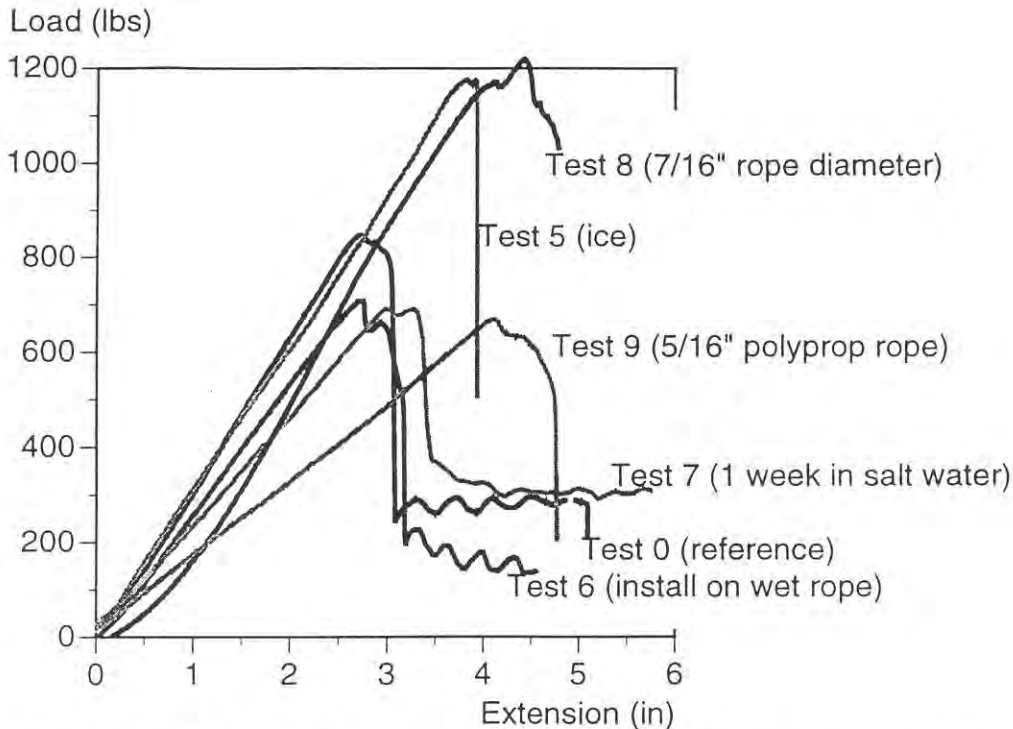

Figure 11: The load-displacement traces of various lap-type links showing the effect of test temperature (TEST 5 vs TEST 0), wet versus dry installation of the shrink tubing (TEST 6 vs TEST 0), exposure to salt water and 20 lbs tension for 1 week (TEST 7 vs TEST 0), 7/16" diameter white rag rope vs 5/16" diameter reference polydac rope (TEST 8 vs TEST 0), and 5/16" worn polypropylene vs 5/16" reference polydac rope (TEST 9 vs TEST 0) on the mechanical response of the link.

#### Effect of Rope Diameter and Rope Type

The links used in TESTS 8 and 9 were manufactured and tested in an identical manner to that for the reference test, except that 7/16" white rag rope with poly-dac tracers and 5/16" worn green polypropylene rope were used rather than the reference 5/16" black and white polydac rope shown in Figure 7. Data from Table I indicates that the failure load increased by approximately 45% to 1219 lbs when the 7/16" white rage rope was used, and that a decrease of about 21% from the reference case occurred when the 5/16" worn green polypropylene rope was used. The results indicate that both diameter and rope type produce a significant variation in failure load. In general, the rope type affects both the coefficient of friction between the contacting overlapped sections of rope and affects the strength of the interface between the adhesive and the rope. The 21% reduction observed in TEST 9 would appear to stem from such effects. The 45% increase observed in TEST 8 has contributions from both the change in rope type and diameter, since both were changed from the reference case. An increased rope diameter alone would be expected to increase the frictional contact area and the adhesive contact area, so that a larger failure load is expected.

FINAL REPORT

DESIGN, TESTING AND EVALUATION OF AN ACOUSTIC  
RELEASE SYSTEM FOR OFFSHORE LOBSTER POT BUOY LINES

Project No. 40EANF800065

Submitted to:

Al Blott  
NMFS, Fisheries Engineering Group, Bldg 61  
East Farm, Kingston Rd.  
Kingston, RI 02881

Joseph DeAlteris PhD  
DeAlteris Associates Inc  
P.O. Box 251  
Jamestown, RI 02835  
401-874-5333 Office  
401-741-1129 Home  
401-789-8930 Fax

30 April 1999

## INTRODUCTION

On 29 September 1998, the National Marine Fisheries Service issued a contract to DeAlteris Associates, Inc. to “design, develop and evaluate, in consultation with the offshore lobster industry, a cost effective prototype acoustic release system for the buoy end line of offshore lobster trap gear.” Additionally, “the system must be compatible with existing lobster gear and equipment” used in the offshore fishery, and the acoustic release must be “capable of distinctive activation codes.” The proposal from DeAlteris Associates Inc. dated 22 September 1998 identified a two phase project designed to meet the requirements of the “Request for Quotation” and the goals of the project.

## BACKGROUND

The Northern Right Whale (*Eubalanea glacialis*) and other large whales inhabiting New England waters have an interaction problem with the buoy line of lobster pots. It is believed that as the whales encounter the lines, they slide along the whale until a knot or buoy is caught in the baleen or joint between body and an appendage. At that point the whale senses the resistance of the gear, thrashes, and becomes entangled. While disentanglement has been successful in some cases, the optimum solution is to minimize the probability of entanglement. This can only be achieved by prohibiting the lobster fishery when the whales are present, or by removing the buoy lines in the water column that can entangle the whales. Unfortunately, buoy lines are required to mark the locations of the gear so lobstermen do not set trawls or traps over each other, and mobile gear fishermen are aware of the presence of fixed gear. Therefore, it has been suggested to use low-strength buoy lines that can be easily broken by entangled whales to mark the end of

trawls of traps, and a remote, acoustically triggered system to release a “pop-up” buoy and hauling line from a canister at the end of the trawl of traps.

Acoustic releases have been used for more than two decades in the moorings of oceanographic instruments in the deep ocean. Typically the equipment includes an acoustically triggered sub sea unit with a motor actuated release jaw that opens and releases a buoyed instrument package from a bottom anchor, and a vessel deck unit that is used to transmit a coded acoustic signal to the sub sea unit. These units are commercially available, off-the shelf, from regionally located manufacturers in both expensive deep ocean models, and low-cost shallow water, continental shelf models.

#### METHODS

The objective of the first phase of the project was to design and develop the prototype acoustic release. The tasks involved in this first phase were:

- (1) Meet with manufacturers of acoustic release instruments and acquire a subsurface release and deck unit for incorporation in the acoustic release system.
- (2) Meet with members of the offshore lobster industry, discuss the objective of the project, and identify operational requirements/constraints for the acoustic release system to be successfully incorporated into their operations.
- (3) Determine design requirements/limitations for the acoustic release system based on hydrodynamic principles.
- (4) Design and construct a prototype system.
- (5) Test this prototype system in relatively shallow water (less than 200 feet) in Narragansett Bay and the adjacent coastal waters.

The second phase of the project evaluated the prototype acoustic release system in the offshore lobster fishery on vessels operating from southern New England and New Hampshire.

This final report presents the results of the both phases of the project.

## RESULTS

### Phase I - Task I. Acquisition of an Acoustic Release Unit

In early October, we met with Bob Catalano of Benthos and Greg MacEachern of EdgeTech. Both firms manufacture shallow water acoustic release devices (Benthos, Model 875; EdgeTech, Model AMD 200). In traditional oceanographic applications, these devices are used to release an instrument package including the subsurface buoy from the mooring anchor, on command. The units are designed to be placed directly in the mooring line with the acoustic sensor (hydrophone) oriented upward, and the release lever oriented downward. Dimensionally, both units are cylindrical (about 18 inches in length and 3 inches diameter) and are mounted in a synthetic strongback. The Benthos unit uses a motor driven actuator that rotates and releases the retaining lever. The EdgeTech unit uses a spring loaded solenoid to release the retaining lever. The subsurface units have an operating depth rating of 1000 feet, a 200 pound load rating, and 6-12 month operating life on conventional dry-cell batteries. Both units operate in the 7-15 kHz range in 0.5 kHz increments, and have programmable digital codes. The operating slant range of the units is about 5 nm (30,000 feet). The cost of the subsurface units is \$2,000 each. The Benthos deck unit (DS-8750) includes permanent internal batteries, a battery charger, a transducer with a 30 ft cable, and is programmable for a wide range of frequencies and digital codes. This unit costs \$5,000. The EdgeTech unit (AMD 200) also includes a transducer with

but operates on 9 volt alkaline batteries. The unit is programmable for a wide range of frequencies and digital codes and costs \$3,000.

Both manufacturers indicate that if demand is appropriate (greater than 1000 subsurface units), they would redesign their shallow water acoustic release device for the needs of the lobster industry, and the resulting subsurface products would be substantially reduced in cost, estimate to be less than \$1000 each. In particular, we discussed the benefits in increasing the operating frequency to 20 to 30 kHz, resulting in a reduced operating range, but gaining a substantial cost savings and reduced power requirement. Additionally, the deck unit would be modified for external power, interior placement in the pilothouse, and a hull-mounted transducer. Again, these modifications would result in substantial cost savings, reducing the deck unit cost to approximately \$2500.

In mid-October, we purchased a Benthos subsurface unit and received on-loan a deck unit. EdgeTech also provided a subsurface unit and surface deck unit, on-loan for testing in the second phase of the project. We evaluated the equipment of both manufacturers in the second phase of the project. We also reviewed acoustic release units/designs from Inter Oceans and Dukane, but neither was appropriate for this application.

#### Phase 1 - Task 2. Determination of Fishery Dependent Operational Parameters

To determine the fishery dependent operational parameters, we interviewed lobster fishermen at Fish Expo, and met with lobstermen from Southern New England and New Hampshire. At Fish Expo, in Boston, October 15-17 1998, we set-up a display of the acoustic release at the information booth operated by the University of Rhode Island, Department of Fisheries. We queried lobster fishermen as to their concerns and operational constraints. In early



November, we met with Nick Jenkins and Will Bland of Little Bay Lobster Co. (Shafmaster boats). We discussed the fishery dependent operational parameters including on-deck operations, gear design considerations, etc. We have also discussed southern New England operational requirements with Capts. Dick Allen, Paul Bennett and Dave Spencer. In general, the offshore fishery operates year-round, in water depths from 50 to 100+ fathoms (300 to 600+ feet).

Lobster traps are constructed of either wood or vinyl-coated wire, with wet weights on deck of 40 to 100+ lbs. The traps are attached to a mainline up to 6000 feet in length, and at spacings up to 300 feet. A typical offshore trawl of traps (6000 feet) includes a maximum of 40 traps at a spacing of up to 150 feet. At each end of the bottom mainline is a hauling line to the surface attached to a marker buoy (60 inch circumference soft plastic float). A weight (100+ lbs) is placed at the junction of the buoy line and bottom mainline to anchor the trawl of traps in place and resist the drag and lift forces due to the buoy line. The hauling line can be as long as 250 fathoms (1500 ft) when working in the deepest water, is usually made of polypropylene, and ranges in diameter from 1/2 to 5/8 inches. During fishing operations, the vessel approaches the float, and places the hauling line into the hydraulic pot hauler. At this point the hauling line becomes an anchor line connecting the vessel to the trawl of traps on the seabed.

Based on our discussions with the offshore lobstermen, we developed the following minimum requirements for the prototype acoustic release system.

- (1) The system must carry at a minimum 1000 feet of hauling line to operationally test the concept.
- (2) The system must be sufficiently rugged to withstand deck operations, but must weigh less than 200 lbs to be effectively handled by the deck crew.

- (3) The hauling line must be of adequate strength to handle the loads of the vessel against the trawl of traps on the seabed (greater than 4000 pounds breaking strength). This precluded the use of a light line, pop-up buoy.
- (4) The hauling line must be of sufficient diameter (greater than 3/8 inch) to work on a pot hauler, set for the larger diameter bottom line and traditional hauling line (1/2 to 5/8 inches).
- (5) Because of the heavy loads on the hauling line, the line will have to be completely removed from the acoustic release system after being deployed. That is the hauling line is not connected to the release system structure, but directly connected to the mainline near the anchor weight.

The acoustic release system, if implemented by regulation, will release a strong hauling line. However, each trawl of traps will have to be marked with at least one buoy at one end to identify the presence of gear, so as to avoid lobstermen setting gear over each other, and interactions with mobile gear fishermen. Therefore, it is proposed to mark the gear with buoy attached to a line with a weak link at the bottom where the buoy line attaches to the anchor weight. In the case of a large whale entanglement, the weak link would break allowing the whale to be entangled only in the line but to be free of the lobster gear. The acoustically released hauling line would be at the other end of the trawl of traps.

### Phase 1 - Task 3. Design Requirements Based on Hydrodynamic Principles.

There are several hydrodynamic issues that must be considered if this proposed acoustic release system is to be successful. The system must be capable of carrying to the seabed and deploying at least 1000 feet of hauling line. The buoy must be capable of withstanding pressure

at water depths up to 150 fathoms (900 feet), must have sufficient buoyancy to drag up to 1000 feet of line to the surface. The larger the buoy, the greater the buoyancy, but then the system will require more ballast, so that the entire system is negatively buoyant and behaves similar to a lobster trap as it settles to the seabed. Finally, the system must be very stable in the upright position; so that it always lands on the seabed upright, and remains that way. Otherwise, the acoustic release will not function properly, nor will the hauling line deploy properly.

The stability of the system in the water column and on the bottom can be assured by separating the centers of buoyancy and gravity. That is, by placing any required ballast on the bottom of the system, and the buoy at or near the top of the system, and separating vertically the centers of these forces, the system will always return to the upright position when disturbed.

The buoyant force of the buoy must overcome the drag of the line in the water column. The magnitude of this line drag is proportional to the length of the line, the diameter of the line, and the velocity of the line through the water squared. Thus a 1/2 reduction in line diameter results in 1/2 reduction in line drag, and a 1/2 reduction in buoyancy required by the float.

Given these two important reasons to reduce the hauling line diameter (a smaller diameter line has less bulk and less drag), we determined the breaking strength of existing polypropylene line used in the fishery to be about 5000 pounds (1/2 inch is 4200 pounds and 5/8 inch is 5100 pounds). We identified a "soft lay", 3/8 inch polyester/nylon double braid with a breaking strength of 5600 lbs, and a relatively low cost of \$225 for 1000 feet. This line random packs into a canister (plastic tub) 19 inches in diameter and 18 inches in height. We also found a relatively economical (\$64), large diameter (14 inch) rigid buoy that provides 38 pounds of buoyancy and has a working depth of 400 fathoms (2400 feet). At the request of lobstermen, we have also

attached an 8 inch diameter, deep-water float about 2 feet from the large buoy to aid in the retrieval of the gear. The combined buoyancy of these buoys is about 45 pounds.

In shallow water, discounting line drag, the terminal ascent velocity of the buoys is calculated by equating the buoyant force (B.F.) of the buoys to the drag (D.F.) of the buoys, and solving for the velocity (V).

$$B.F. = D.F. = 1/2 \rho V^2 C_d A$$

The drag coefficient of a sphere is assumed to be 0.5, and the projected areas of the two buoys are (0.050 m<sup>2</sup>). Using the density of seawater at 102 kg/m<sup>3</sup>, the predicted terminal velocity is 10.7 ft/sec (3.5 m/sec).

Using the same rationale, but including the drag of the line, it is clear that as the length of the line in the water increases with water depth, the float ascent velocity decreases. For example, in 100 ft of (30 m) of water, terminal ascent rate is 6.9 feet/sec (2.24 m/sec); and in 600 ft (200 m) the terminal ascent rate is 3.3 feet/sec (1.08 m/sec). Thus, line drag results in a significant reduction in the buoy ascent rate. In 100 feet (30 m) of water, the ascent time is estimated to be 11 seconds; and in 600 feet (200 m) of water the ascent time is estimated at nearly 120 seconds (2 minutes). Deeper depths requiring longer lines may require 2 large buoys, rather than large and small buoys.

#### Phase 1 - Task 4. Design and Construction of a Prototype Acoustic Release System

The results of the previous tasks provided the essential elements of the system that had to be incorporated into a functional design.

- (1) The acoustic release must be vertically oriented with the hydrophone upward.

- (2) The large and small, hard plastic buoys must be retained in the upper portion of the system until deployed, and separated by a vertical distance from the ballast which should be placed as low as possible in the system. Additionally because the buoys provide about 40 pounds of buoyancy, the ballast must provide at least 50 pounds of negative buoyancy.
- (3) The device must be of sufficient size to carry the hauling line canister (19 inch diameter and 18 inches in height), and the canister must be easily removable and reloadable during regular vessel operations. The hauling line has eyes at each end, that are fastened to the release buoys and the junction of the system bridle and the lobster pot trawl groundline, respectively. After each deployment, a spare empty canister is placed under the pot hauler, and as the line is taken aboard, it is directly reloaded into the canister. This results in an end for end rotation of the hauling line after each use, and an exchange of canisters.

We constructed the device using 12 gauge, 2 inch square, vinyl-coated lobster trap wire.

The initial design had a high-aspect ratio (height is about two times greater than the base) and is shown in Figure 1. The base is 22 x 26 inches, and the height is 56 inches. The device is divided vertically into three sections, the lowest section retains the four ballast bars of 25 pounds each, the mid-section retains the hauling line canister, and the upper section carries the acoustic release unit, the hard-plastic buoys, and the feeder line tube from the hauling line canister to the top of the device. The upper section is sub-divided into compartments with wire mesh partitions.

Overall, the dry weight of the system is about 180 pounds (40 pounds of line, 100 pounds of ballast, 25 pounds of buoys, and 15 pounds of wire, plastic, etc.). The final design had a low-aspect ratio so as to more closely resemble a lobster trap and is shown in Figure 2. The revised design has a base 46 x 24 inches, and a height of 32 inches. The device is divided into several compartments with four ballast bars at the base, the hard plastic buoys are in the mid section, the

hauling line canister is at one end and the acoustic release is at the other end. Again, the dry weight of the system is about 180 pounds.

Several methods for storing the hauling line in the canister were evaluated. The simplest was the random pack. Other methods included a hollow central core and a spool. The random pack method proved to be not only the simplest, but also the least likely to snag. However, even with this method, some care must be exercised in the reloading/repacking process.

#### Phase 1 - Task 5. Initial Design Prototype Testing

The initial design, high-aspect, prototype system was tested on several occasions in late December 1998. On the first day, the shackle and line from the acoustic release device to the buoys snagged when the lever was released. This required some redesign and reconstruction of the upper portion of the device, so as to ensure that the tension and travel of the release shackle was directly downward, until the shackle passed around a bar and then moved upward with the buoys. Additionally, the shackle was replaced with a ring, so as to further reduce snags.

On the second day of testing, a diver checked the stability of the system on the seabed. Essentially the system could be rolled over, and it returned to the upright position. It was deployed from the vessel sideways, and always landed on the seabed in the upright position. The system also successfully released the buoys and hauling line in shallow water (20 feet). The ascent rate of the buoys in shallow water was timed at 10 feet/sec.

On the third day of field evaluation, the system was tested once in shallow water (30 feet) and twice in relatively deep water (90 feet). On all of these occasions, the buoys were released, and rose to the surface. The ascent rates were 10 ft/sec in shallow water and 8 ft/sec in deep water. The final day of Phase I field testing was conducted on 28 December 1998 in 120 feet of

water in a deep channel in the East Passage of Narragansett Bay. The system was tested twice. On the first trial, the buoys released, but the hauling line reached a snag in the tube after 60 feet of line deployed. The device was retrieved, reloaded, redeployed, and operated successfully on the second attempt. Again, the mean buoy and line ascent rate was timed at 8 feet/sec.

#### Phase 2. Design Revision and Offshore Testing and Evaluation

The final design, low-aspect, prototype was constructed in January 1999. The purpose of the revised design was to reduce the potential for snags in the hauling line as it passed from the canister, through the conduit and out of the device. The canister was further modified with a cross pattern of elastic-shock cord to retain the random pack hauling line. As the 1000 foot line only required 60% of the canister, the shock-cord was placed at the 60% level. The shock-cord retainer can be lowered or raised as the quantity of hauling line is changed.

In mid-February 1999, the low-aspect prototype was tested from the F/V Ocean Pearl in 150 feet of water in Rhode Island Sound. The EdgeTech release was used initially, but had several occasions when the release did not function. The Benthos acoustic release was then installed and 8 of 10 sets were successfully completed. On the last two sets, the hauling line snagged on deployment, after the acoustic release triggered. In each case, the problem was related to slack in the shock-cord line retainer. The EdgeTech acoustic release was returned to the factory and apparently had failed due to an electronic malfunction.

In mid-March 1999, the F/V Ocean Pearl was again chartered to further evaluate the low-aspect prototype design. The shock-cord line retainer was replaced prior to the testing. The unit was successfully set, released, and hauled 20 out of 20 attempts. The modified shock-cord line retainer was deemed a success at preventing snags in the hauling line deployment.

In early April 1999, the low-aspect prototype was tested aboard the F/V Eulah McGrath in the Gulf of Maine. The water depth was approximately 300 feet. Our acoustic release unit was installed in a short trawl of traps, and was successfully set, released, and hauled 19 out of 20 attempts. On the last set, the hauling line was incorrectly attached to the acoustic release, so although the release functioned properly, the buoy did not deploy. The first 10 sets were accomplished using the Benthos release, and second ten sets were accomplished using the EdgeTech release.

### SUMMARY AND CONCLUSIONS

The purpose of the project was to design, test, and evaluate an acoustic release system for offshore lobster buoy lines. Over a six month period in 1998-1999. We accomplished the following:

- (1) Interviewed lobster fishermen as to their operational requirements for the system.
- (2) Researched shallow water acoustic release equipment available from manufacturers.
- (3) Analyzed and identified system constraints and developed a conceptual design.
- (4) Developed, constructed, and tested an initial, high-aspect, prototype design.
- (5) Revised the initial design to a low-aspect design, and constructed and tested that unit.

The final product is a system that carries 1000 feet of hauling line, and will operate up to water depths of 600 feet. The final design was successfully tested 39 out of 40 attempts. The only failure was an operator error. The system was successfully tested at sea aboard lobster fishing vessels in the Gulf of Maine and Southern New England.

The objective of the project was to demonstrate a "proof of concept." We have developed a system that will provide lobster fishermen an alternative if the regulations are



enacted that prohibit buoy lines in the water column. The solution is not inexpensive; but given the alternative of not being able to set and haul gear or having to grapple for gear with no buoy lines, this solution may be attractive. We have only demonstrated the concept. We expect that individual fishermen will improve the design of the system as they work with it, if and when that time comes.

#### ACKNOWLEDGEMENTS

The project could not have been accomplished without the assistance of the lobster fishermen, and in particular Capts. Nick Jenkins of Little Bay Lobster and Dick Allen of the F/V Ocean Pearl. Neil Thompson was invaluable in the implementation of the field studies, Dave Beutel assisted with the gear construction, and Laura Skrobe assisted with reports.

#### LOBSTER FISHERY CONTACTS USED IN THE PROJECT

Capt. Paul Bennett  
F/V Hedy Brenna  
89 Paradise Ave.  
Middletown, RI 02842  
Tel: (401) 847-1329

Capt. Dave Spencer  
F/V Nathaniel Lee  
20 Friendship St.  
Newport, RI 02835  
Tel: (401) 423-2120

Capt. Will Bland and Nick Jenkins  
Little Bay Lobster (7 offshore vessels)  
18 Old Dover Rd.  
Newington, NH 03801  
Tel: (603) 431-3170  
Fax: (603) 431-3496

Capt. Dick Allen  
F/V Ocean Pearl  
35 Bliss Road  
Wakefield, RI 02882  
Tel: (401) 789-1463

Ms. Bonnie Spinazzola  
Executive Director: A. O. L. A.  
114 Adams Rd  
Candia, NH 03034  
Tel: (603) 483-3030  
Fax: (603) 483-4862

ACOUSTIC RELEASE MANUFACTURER CONTACTS USED IN THIS PROJECT

Robert Catalano  
Benthos  
49 Edgerton Drive  
North Falmouth, MA 02556  
Tel: (508) 563-1000  
Fax: (508) 563-6444

Greg MacEachern  
EdgeTech  
455 Fortune Blvd.  
Milford, MA 01757  
Tel: (508) 478-9500  
Fax: (508) 478-1456

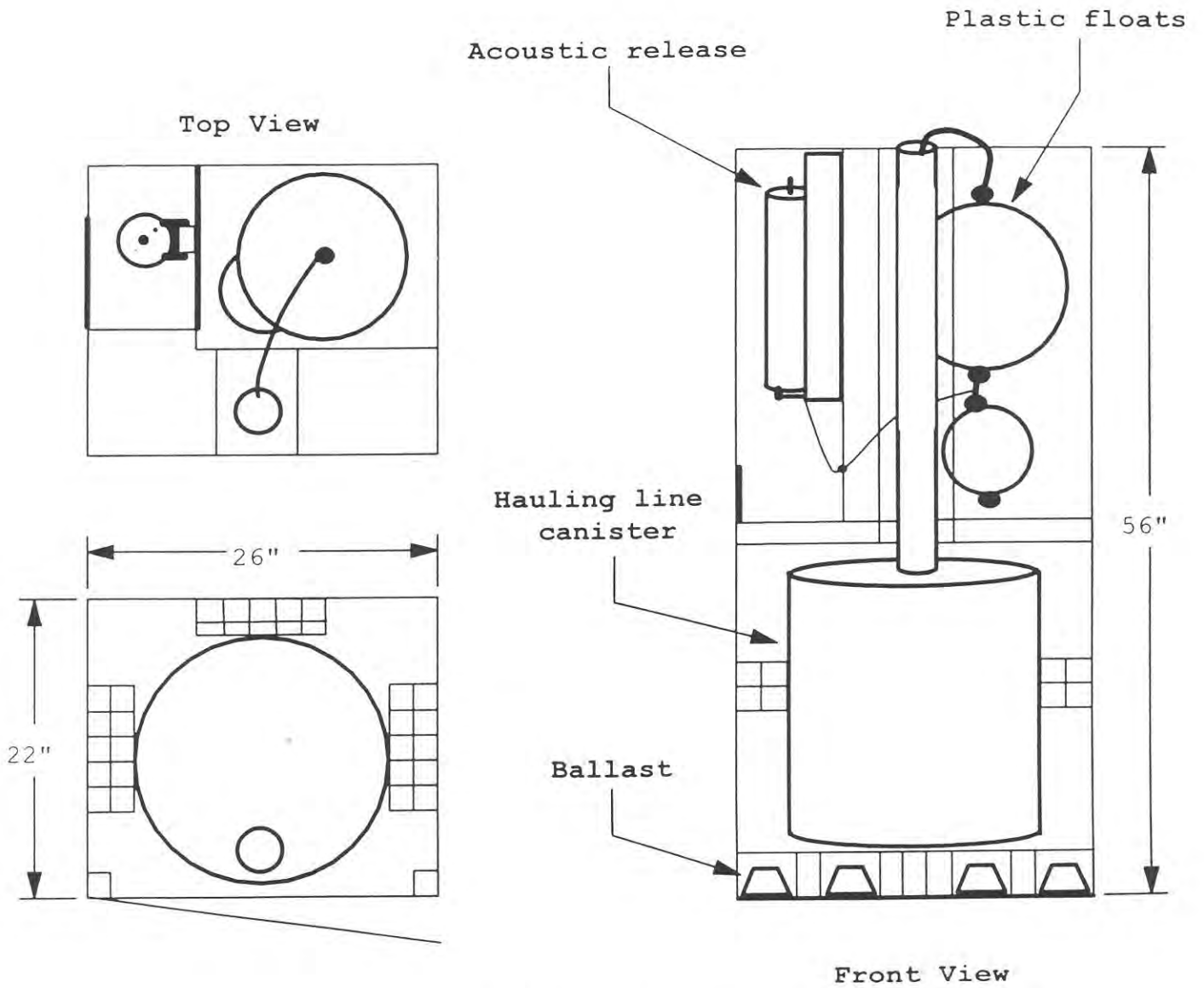

Scale: 1"=12"

Figure 1. High aspect, initial design, for hydroacoustic release system.

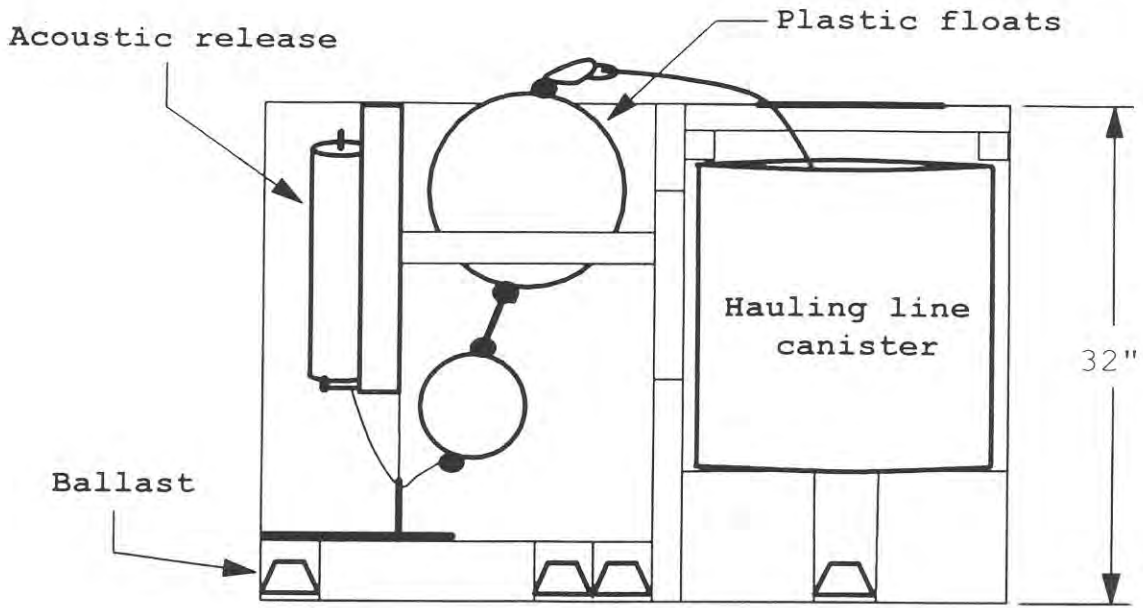

SIDE VIEW

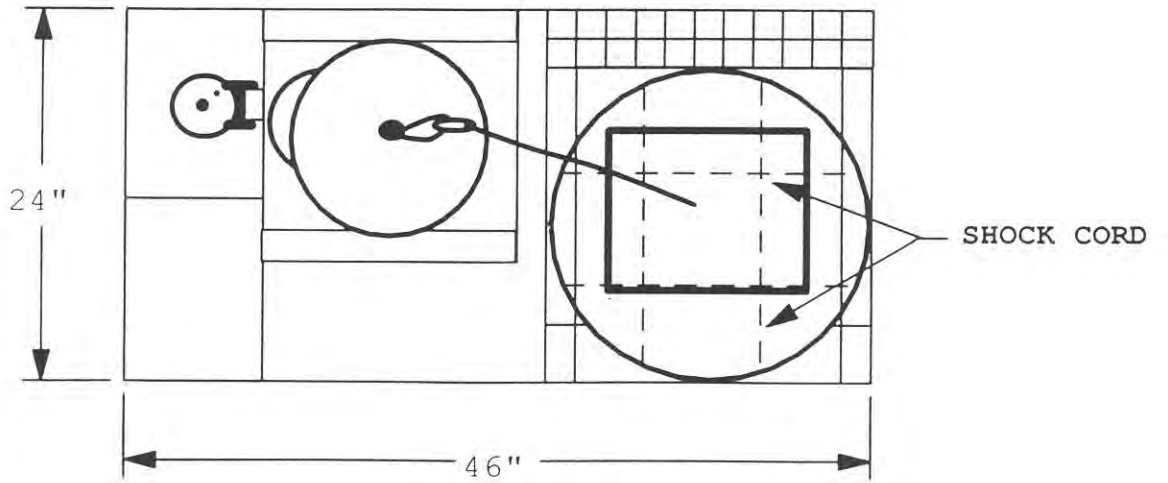

TOP VIEW

Scale: 1"=12"

Figure 2. Low aspect, final design, for hydroacoustic release system.

**Development of Bottom Weak Links  
and  
Buoy Line Messenger System**

Prepared by

**Ronald Smolowitz**  
Coonamesett Farm

and

**David Wiley**  
International Wildlife Coalition

Prepared for

**National Marine Fisheries Service**  
Gloucester, Massachusetts

**December, 1999**

## INTRODUCTION

The intent of this project is to test and refine prototype systems for the retrieval of lobster pot trawls and gill net strings. The retrieval systems are for hauling fishing gear designed with lower breaking strength connections located at or near the sea floor. These low breaking strength connections are part of a program to reduce the risk of entanglement of right whales in bottom set fishing gear. The project set-out to accomplish the following tasks:

1. To re-design, test and refine a prototype system that uses a messenger type device to descend down a low strength buoy line to a fixed gear trawl or string and retrieve that string.
2. To re-design, test and refine a prototype system that uses a timed release device located on the fixed gear that will provide for a delay after a predetermined load is applied. The timed delay would allow time for a fisherman to retrieve gear that might require higher than normal hauling loads (fetched-up on bottom) before the release parts, but allow for an entangled whale to break free of the gear at the end of the timed interval.
3. To complete a written report presenting the results of the testing and engineering drawings of the devices.

### Background

The northern right whale is the world's rarest species of large whale. During over a half-century of protection, the species exhibited slow, but identifiable population growth (Knowlton et al 1994). However, recent analysis suggest that within the last decade the population has begun to decline and, if current trends continue, may be extinct in less than 200 years (Caswell et al. 1999). Evidence suggest that the recent decline is concurrent with an increase in serious injury and mortality attributable to ship strikes and entanglement in commercial fishing gear (Knowlton 1998, Hamilton 1998). The Endangered Species Act (ESA) and the Marine Mammal Protection Act (MMPA) require that actions be taken to reduce the factors responsible for these mortalities. Conflicts arise because commercial shipping and commercial fishing constitute the dominant human activities that take place in the marine environment. Each activity is widespread, and each is of major economic and social importance.

Efforts to mitigate negative anthropogenic impacts are complex undertakings. The right whales use of waters of great economic importance to humans, combined with the difficulty of identifying where whales are likely to be found, can confound protection based on straight forward measures such as excluding human activity from areas used by whales. An alternative to separating whales and high-risk human activities is to modify the human activity to reduce the element of risk to whales. Ideally, this approach protects whales and allows human activity to continue. In this report, we provide a brief summary of some of our previous work to develop

modifications to sink gill nets and lobster gear. These modifications are designed to reduce the risk of right whale entanglement and the effects of such entanglement should it occur. More detailed descriptions can be found in Wiley et al. (1997) and Smolowitz and Wiley (1998).

Sink gill nets, lobster traps and their associated lines are the gear types most often implicated in right whale/fishery interactions. However, the actual number of interactions for each gear type is quite low (i.e., a few each year). This low rate of interaction, combined with the legal, financial, and practical difficulties of designing controlled experiments involving wild, endangered whales, precluded normal types of hypothesis testing. Instead, our investigations rely upon empirical (observational) studies. The studies are designed to gain insight into the potential behavior of fishing gear relative to whale entanglement. We then use such insights as an aid to problem solving. Our research approach uses an inclusive model with participants and observers from the conservation, fishing and regulatory communities. Procedures involve making predictions about how the gear would respond to whale-like encounters, simulate such encounters, and then observe the outcome of the experimental trials. Confidence in our results is established by repeating and modifying trials until the questions and concerns of all observers are satisfied. While the trials do not, nor were they intended to, result in statistically significant results, they do provide insights important to problem framing and solution.

### **Lines associated with lobster traps and gill nets**

Lines associated with lobster traps and gill nets are known to entangle whales. Lines of concern include the vertical buoy line that extends from surface buoys to traps or nets on the sea floor. This line is used to connect the buoy, which marks the position of the gear on the sea surface, to the actual fishing components of the gear (traps or nets). The buoy line is also used to set and haul the gear. In sets of multiple traps or nets, the gear may have a buoy line at each end in order to mark the location of the string more accurately and to allow the gear to be hauled from either end as conditions warrant. There are also lines that run on or above the sea floor joining multiple lobster traps into trawls or strings (**Figure 1**). These lines are sometimes referred to as ground lines. Gill net strings usually have the individual nets tied together with short connecting bridles forming long, semi-continuous walls of netting (**Figure 2**). The top portion of this wall is supported by a float line and the lower portion is held in place by a lead line. Both float lines and lead lines are potential entanglement risks.

### **Modification to vertical lines**

A whale can become entangled in the vertical line when it strikes the line and an obstruction, such as the surface buoy, becomes snagged on the animal (**Figure 3**). Under this scenario, a modification that would allow the surface buoy to release from the line might eliminate or reduce the threat of entanglement (**Figure 3a**). To investigate the "pop-off" buoy concept in a previous project, we arranged to meet with groups of fishermen at the Massachusetts Maritime Academy's Strength of Materials Laboratory (Buzzards Bay, MA) and

at the Strength of Materials Laboratory at the Woods Hole Oceanographic Institute (Woods Hole, MA). Fishermen, the conservation representative and the fisheries engineer presented a number of possible solutions for testing and acceptance by the group. Gear configurations were tested for breaking strength, and then considered for ease of use, rigging expense, and enforcement. Considerable discussion occurred during these sessions, with fishermen supporting breaking strengths as high as possible and the conservation biologist wanting breaking strengths as low as possible. The iterative nature of the process, with all interest groups observing the tests, participating in design discussions, and observing re-tests, was key to the final acceptance of the results.

We ultimately devised a weak connection that parted at about 400 lbs. The connection consisted of five, 3/4 inch stainless steel "hog rings" clamped to join the buoy line to itself. When pressure is applied to the buoy, the rings fail and the line runs free, theoretically releasing the obstruction and whale. This is an operationally simple device using low cost materials the fishermen already possess. Its use seems relatively easy to observe and enforce, and it seems capable of reducing the risk of whale entanglement. Subsequent at sea operational testing by fishermen indicated that they could use the 400 lb breakaway device without losing gear under some conditions. Whether this is weak enough to satisfy the needs of whales is less clear.

#### Bottom breakaways

Our next attempts involved the creation of a release point located at the bottom of the vertical line. Whereas a weak link located at the surface buoy might prevent or minimize the effect of entanglement involving animals contacting the buoy, entanglements also occur when an animal collides with the vertical line and becomes entrapped before contacting the surface buoy. In this situation, a surface buoy breakaway would provide no benefit.

To alleviate this hazard, the breakaway or release point must be located near the bottom, where the vertical line attaches to the trap(s) or net(s), or else the entire line would have to be made of a weak material. However, either of these scenarios is practically and theoretically difficult because a link or line weak enough for whales to break free of would also break when a fisherman attempted to haul the gear. To investigate these concepts, we worked to devise a messenger system to use with an entirely weak vertical line and a delayed release system to function as a bottom release device (**Figure 4**).

#### Messenger System

The messenger system is patterned after the common oceanographic practice of sending a weighted device down a line to perform a function at the ocean bottom. In the case of a "whale messenger", the device would provide a way to send a heavy hauling line down a light, easily broken "tag" line that is attached to the trap(s) or net(s). Once the messenger is attached to the traps, the heavy hauling line is used to retrieve the fishing gear.



A prototype whale messenger was built by Jeffery Goodyear of the Ecology Research Group (Sunderland, MA). As a part of the project reported here, the "Goodyear Grabber" was successfully tested in field trials with a Maine lobster fisherman, and Glenn Salvador of the National Marine Fisheries Service and Maine Department of Natural Resources. A second-generation device was then produced to deal with operational handling issues (e.g., quick attachment and removal of the device from the tag line). In addition to Dr. Goodyear, we are working with several machine shops to produce different versions of the messenger system. The messenger system seems to represent the best immediate solution to the current vertical line dilemma. While substantial operational issues need to be resolved, all are technical in nature and achievable.

#### Delayed release system

We are working with Frank Tornngren of Neptune Inc. (Attleboro, MA) to develop a breakaway device that is time (as opposed to force) sensitive. This delayed release device would permit gear to be hauled for a pre-specified period of time. Once the time limit is exceeded, the line releases from the gear. Similarly, an entangled whale would be released from the gear, although not necessarily the line, after the time limit had been exceeded. The delayed-release component is not activated until an initial force of about 400 lbs has been exceeded. The 400 lbs represents a presumed maximum loading threshold that might be exerted by natural environmental forces. Previous to this project, a prototype of the device had been built but not tested.

We believe that the modification of fishing gear represents the best solution to the vexing problems involving the entanglement, serious injury, and death of right whales. However, both the fishing and conservation communities have cause to view gear modification with caution. Fishermen have concerns as to whether modified gear will be as productive, safe, and operationally viable as traditional gear. In addition, many fishermen have philosophical difficulties with being forced to change their style of fishing. Even relatively simple operational changes might be rejected, not because they are overly intrusive, but because they strike at the heart of who a fisherman is and why he or she fishes. Therefore, gear modifications are likely to be embraced only when alternative measures are more onerous (e.g., extensive time and area closures).

Conservationists have other concerns. Because it is impractical to test gear modifications on actual whales, it is difficult to quantify or predict their success in reducing whale mortality. Additionally, fishermen can easily circumvent unwanted modifications at sea, where regulations are seldom enforced. Therefore, even when modifications are developed and required, their effectiveness can be suspect. Because the effectiveness of gear modifications can not be demonstrated prior to use, management recommendations involving them must be continuously evaluated. Ideally, its products should be incorporated into an adaptive management approach as described by Lee (1993) and Walters (1997).

## Buoy Line Messenger System

Coonamessett Farm, in conjunction with the International Wildlife Coalition, was funded by the Massachusetts Environmental Trust in 1997 to examine the issue of right whale entanglement in fishing gear. As a part of that project a prototype model buoy line messenger was built, to illustrate the concept, but never field tested. We will refer to this prototype as a jam cleat style messenger (**Figure 5**).

The Goodyear Grabber is the original prototype jam cleat style messenger. It basically consists of a heavy steel cylinder with a large diameter slot running the full length. The slot has means to enclose up to a 1/2-inch diameter line. At the top end of the slot is a jam cleat. The concept is that fishing gear would be set with a small diameter low breaking strength buoy line attached to the gear at the bottom with a higher strength hauling line pennant. The messenger is designed to slide down the small diameter tag line with a hauling line attached. Upon reaching the bottom set fishing gear the hauling pennant would pass through the jam cleat allowing for the gear to be retrieved.

The prototype Goodyear Grabber messenger had a number of potential problems associated with the conceptual operation. Two key questions have to do with line fouling and determining when the hauling pennant has been captured. In this project we conducted a field test of the existing prototype, re-designed the messenger based on these initial tests, built several second generation prototypes, and conducted limited field testing of the new units.

### Field tests of Goodyear grabber messenger

The initial concept of using the messenger was that the buoy line would be of small diameter, with a breaking strength of about 500 pounds. This would terminate down at the gear into a larger diameter pendant. Some difficulty was encountered joining the two lines together. The twisted nature of the 3/8 poly pendant did not "meet" with the braided nature of the 5mm small diameter line commercially available. Therefore, a traditional splice was not possible. To join the two lines together, we wove the braided poly through about 2-ft of the twisted poly. Test pulls indicated that this arrangement could withstand substantial force, at least sufficient for hauling the cinder block in initial land trials. Initial land tests with the grabber resulted in the grabber becoming stuck at the juncture between the two lines. To alleviate this problem, we used electrical tape to wrap the joined area. This provided a smoother transition area between the two lines. Subsequent land tests demonstrated that the Goodyear Grabber could easily pass down the entire line, with the area joining the two lines presenting no inhibitory affect.

To test the apparatus, we chose a dock with approximately 10 - 20 feet of water below it. This site was chosen because the water was deep enough to provide some degree of reality to the test. However, the water was shallow and clear enough to allow us to observe the process, and allow us to dive and retrieve the grabber if difficulties arose.

To test the device, we tied a 6 foot length of 3/8 poly to the cinder block. The 5 mm "tag line" was woven into this piece and acted as the surface line for the block. The block was then lowered into the water. In the initial tests, we took up on the tag line until it was taught, and then carefully lowered the grabber down the tag line. Once we could see that the device was next to the block we hauled back. In each instance (n=10), the grabber successfully retrieved the block. We then simulated more natural conditions by throwing the grabber off the pier. We then tightened up on the tag line until the grabber met the block and hauled back. Each time the grabber successfully engaged the heavy hauling line attached to the block and retrieved it. It should be noted, however, that in each instance, the block was directly or nearly directly below the pier. We do not know how well the grabber would work if there were a less than perpendicular angle between the hauler and the object to be hauled.

September 20 - 24 - Trip to Maine to field-test the Goodyear Grabber with NMFS representative Glenn Salvador and Maine lobster fisherman Steven Biot.

Initial success in the semi-field trials led us to contact Glenn Salvador of the NMFS to conduct trials with fishermen under actual fishing conditions. Trials were conducted with lobsterman Steven Biot of Kittery Maine aboard his fishing vessel; a 35-foot lobster boat equipped with standard lobster hauling equipment. Tests were made over a two-day period in water depths of approximately 100 feet.

Day 1 - Tests were conducted by attaching the 5mm tag line with 6 ft of 3/8 poly to one of Mr. Biot's trawls. The trawl was set in approximately 100 feet of water and consisted of 5 traps. The messenger was sent down the tag line, attached itself to the heavy haul line and retrieved the traps. As with our pier tests, the first attempt was made by keeping the tag line taut, and carefully sliding the grabber down the line. After successfully repeating this process several times, we let the grabber "free-fall" down the taught tag line. This method also resulted in successful attachments to the haul line and trap retrieval. We then allowed the tag line to be slack and the grabber to free fall. We then hauled on the tag line to send the grabber to the haul line. This method worked several times. We then tried a quick jerking of tag line assuming that action might be the one most likely to be used by fishermen actually engaged in fishing. This put too much strain on the tag line, and it parted where the two lines were joined. It should be noted that the two lines were joined only by weaving the 5 mm line through about two feet of the twisted poly and was not considered a particularly appropriate or strong joining configuration.

The repeated hauling of the traps also allowed us to observe how the traps behaved in relation to being hauled and problems that would be encountered attempting to get traps on

board the fishing vessel. A problem to be overcome consists of getting traps aboard the vessel. Once the messenger becomes lodged against the snatch block, the traps can no longer be hauled because the messenger blocks the snatch block. The messenger must be removed. However, an additional problem exists because the trap is on the haul line. Under normal circumstances, the trap is on a line that leads to the haul line, allowing the traps to be brought aboard in a continuous motion. Under the present messenger configuration, the trap would have to be brought through the snatch block and hauler, an impossible situation.

Upon reaching the dock, we concentrated on making improvements to the system. We gathered at Steven Biot's barn and he spliced a new line tag line into a stronger, short 3/8 inch line to be attached to the traps. He also spliced a short 15 foot line into the short line to be attached to the trap. This line had a cork float attached to the bitter end. Also spliced into this line was a line that would lead to the next trap. This line was to be used to haul the traps once the messenger had become lodged against the snatch block. A new line would have to be tied to the davit from which the snatch block is hung. This would have a clip. When the messenger came lodged against the snatch block, the fishermen would use the line leading from the davit to clip to the pot and hold it in place. The messenger would then be removed, the short floating line gaffed and used to haul the next trap.

Day 2 - We used this system to haul a trawl of two traps. The traps were arranged so that both traps would be in the water column during hauling, therefore assuring that the strength or holding capacity of the grabber could withstand the weight of two traps. We repeated our pattern of first slowly lowering the messenger down the taught trap line, then "tossing" the messenger down the taught tag line. Both of these methods met with 100% success. We then tossed the messenger down a slack tag line and hauled on the tag line to send the messenger from the spot on the tag line it occupied when the messenger contacted bottom to the trap. This method worked some of the time, but on several occasions the messenger grabbed a portion of the tag line before it reached the traps. With a lighter tag line, this would have resulted in the tag line being broken during hauling and the traps lost. We concluded that the tag line should be kept taut when deploying the messenger.

#### Discussion of results

One user friendly problem consisted of too many lines on the bottom of the boat, as both the tag line and the messenger haul line end up on the deck. One possible solution is that a crew person coil the tag line into a bucket or container as it is retrieved. A more technically sophisticated approach is that the messenger system may require an extra take-up reel or pot hauler for the extra line.

The choice of the tag line also involves some major considerations. Our initial concept was that the tag line would be a small diameter line with a breaking strength of about 500 pounds. The only commonly available commercial line with this low breaking strength are 3-5

mm in diameter synthetic braids. The small diameter creates handling difficulties on deck and also may pose a risk of whale injuries since it is more likely to cut the whale's skin. Also, the small diameter is more susceptible to abrasion failure especially with a messenger routinely sliding down. Pot haulers are not currently designed to handle small diameter line. This approach also leaves the issue of connecting a small diameter line to a larger diameter line.

These problems associated with the small diameter line led us to re-think the concept of the entire buoy line being weak versus the concept of a bottom weak link. We initially considered that a weak line may be more enforceable than a bottom link. However, there are a number of bottom weak link design-options. With the jam cleat style of messenger, the messenger needs to pass over the weak link connection. In addition, with the jam cleat messenger the trap hauling pennant should be braided polyester or other soft construction; not hard twisted poly. The hard twisted poly, especially when wet, is not held tightly by the jam cleat. The weak link would be inserted between the braided hauling pennant and the twisted poly buoy line. One concept would be to hog ring the two lines together in a manner so that the jam cleat messenger can slide pass the joint (**Figure 5**).

Most large jam cleats, used mostly for securing running lines on sailing vessels, are rated for 500 pound working loads. We did not have the opportunity under this project to test the actual loads required for the line to slip through the jam cleats. We did search for other jam cleat type devices that were rated for higher loads and came upon the "Chicago Grip" built by Klein Tool Company (**Figures 6 & 7**). These grips are made to haul steel wire and many are rated above the expected loads for hauling fishing gear. However, these devices are only rated for steel wire, not synthetic line. We did test a Chicago Grip on synthetic line and found that it worked quite well. To meet the manufacturer's recommendation for safe use the hauling pennant would have to be constructed out of wire rope. Connecting wire rope to synthetic line is common practice on sailboat halyards. In our application we would require a weak link at this juncture.

We did explore another possible approach to messenger design using the concept of a gate latch. The latch style messenger uses a latch to connect to metal ring or similar device on end of hauling pennant (**Figures 8 & 9**). The latch style messenger can be designed so that it does not need to have the gripping mechanism slide over the weak link connection as in the jam cleat, it just grabs beyond the weak link connection. The buoy line can either be weak or a weak link needs to connect the buoy line to the ring. Our initial prototype of this style messenger consisted of an inexpensive gate latch attached to the end of a messenger weight held to the buoy line by two snap clips. Upon sliding down the buoy line the latch mechanism contacted a scallop ring attached to the hauling pennant. This contact depressed the latch which then overlapped the ring and closed securing the gear. The prototype was tested on dry land and worked most of the time but not often enough to justify in water tests. The main problem was that the single latch mechanism has to contact the ring in the proper orientation to open.

A second prototype, the "squid", was constructed with a latching mechanism that can function regardless of the orientation upon contact. The squid consists of a hollow cylinder with four evenly spaced tentacle-like pivoting latches located around the bottom. Each latch is shaped like a door latch. A machined plastic striker plug is located on the lobster pot pendant. The squid's tentacles slide over the tapered section of the striker plug then hook onto a machined shoulder on the plug. The weak link would be located where the buoy line attaches to the striker plug. The prototype squid was designed so that it hinges open for east attachment to the buoy line. However, this is not necessary. A simple pair of G-hooks, sometimes referred to as sister clips, just below the buoy, can allow the squid to be inserted over the buoy line. The squid can be cast with four holes along the bottom rim into which the tentacles can be pinned.

The prototype squid works but can be improved. The pivoting freedom of the tentacles needs to be restricted. This design change, in combination with small spring mechanisms to provide positive seating pressure, would ensure that the tentacles are properly oriented even at extreme approach angles. In addition, a method for quick release upon retrieval is needed.

There are several aspects to the messenger approach that are common to all styles. The first is that there is still an unknown messenger weight requirement for different depths; sea states. The second issue is that weak buoy line or bottom weak link may require a low drag buoy system to minimize loss due to weather. On the plus side, costs are kept low because the fisherman only needs one messenger plus a spare. There has been some thought given to a messenger design that does not need to have a hauling line attached. The messenger would simply slide down the line and in some manner negate the weak link. The design problem is how to relay the success of this action to the fisherman so he knows it is safe to haul.

### **Timed Whale Release**

As part of the Massachusetts Environmental Trust project mentioned previously, a prototype of a timed bottom release was designed and built under a sub-contract with Neptune Inc of Addleboro, MA. Neptune has been in the business of designing and selling plastic molded devices to the fishing industry which include buoy sticks and traps.

The Neptune design is an all plastic device that functions as a dash pot (**Figures 10 - 12**). The buoy line is attached to the bottom set gear by means of a sleeve that tightly fits into a cylinder. When force is applied to the buoy/hauling line the sleeve expands against the cylinder and begins to slip at a predetermined load. The rate of slippage is a function of sea water passing through an orifice between sleeve and cylinder. After a designed time period the sleeve leaves the cylinder and the line is released from the sleeve.

The initial prototype was laboratory tested and several conceptual problems surfaced. The binding between the sleeve and the cylinder surface was not consistent. The cylinder and sleeve were also larger than needed. In addition, the flow rate through the orifice may be subject to a

number of variables such as water depth, sediment, and fouling. In this project we re-designed the bottom timed release based on the initial tests, built a second generation prototype (Neptune, Inc.), and tested the new unit.

#### Design objectives

The critical design objectives of the Whale Release with a focus on its designed intent are:

1. The design is a bottom release, to have a 400-lb. pre-load for normal drag on the static line from wind, waves, and currents that pull the buoy marker.
2. When hauling gear the release would take a heavy strain of approximately 1000 lb. for a period of time to allow gear to be hauled aboard.
3. If a mammal were entangled in the static line the line would have no knots or attached components when released from the Whale Release
4. If a mammal were entangled the release would function after a timed interval.
5. The Whale release would stay attached in its entirety to the traps or bottom gear.

The release consists of four parts: the cylinder, piston, tapered grip split sleeve, and valve. The Whale Release can be reset to the closed position with a fixture that pushes the tapered grip split sleeve and piston to a closed position allowing any water between piston and cylinder to escape via a valve.

#### Description of operation

The Whale Release functions by encapsulating the end of static line nearest the lobster pot. The tapered grip split sleeve is allowed to move 1 1/4 inch when a pull force is applied. A 2-degree included taper inside the piston compresses and grips the static line. When the tapered grip split sleeve end butts against the front end of the piston it causes a vacuum between piston and cylinder. This causes water to be pulled slowly through a valve, at a metered rate, giving the piston a timed forward movement. At a given point, the static line releases from the Whale Release.

#### Test set-up/apparatus

Two trees, a block and tackle, and a 200 lb spring scale were used to determine what load the Whale Release could hold and how much time it took to function through its cycle. The cylinder was attached to the base of one tree via rope. The block & tackle and a static line

sample were tied five feet high in the second tree approximately twenty feet apart. The static line was placed into the piston and then the piston into the cylinder. The 200-lb scale was tied to the pull end of the block and tackle, then a rope was tied to the other end of the scale. In this arrangement the scale reads one fifth of the pull force applied to the Whale Release.

#### Test results Phase One

The first test was a dry run. The rope grips functioned to perfection by sliding the 1¼ inch stroke to tighten around the static line sample. The gripping occurred with about a 100-pound pull load. As the pull load increased to about 80 pounds on the scale (400 pounds on the Whale Release) the piston, 2 grips, and the static line sample were released instantaneously. This indicated that the piston and cylinder timing did not work without water in the system. The test was run several additional times using water in cylinder, to get hydraulic pull, with the same results.

It was decided to tighten up on clearance of the wall between cylinder, piston and o-rings. So, we installed a small sleeve at the far end of cylinder to achieve the reduction in clearance. The results were the same; an instantaneous release between 300 - 400 pounds pull force. It was then decided that the check/metering valve might not be sealing properly due to insufficient sealing spring pressure against the valve seat. Varying shims were made and placed under the finger spring to increase the spring force holding valve in position. Results were the same; instantaneous release between 300 - 400 pounds pull force.

It was next decided to remove the check/metering valve and replace it with a solid press fit plug to allow no water flow. This would demonstrate the piston to cylinder sealing capability only. The results were that you could not push piston in due to water in front of piston. When water was left out, the trapped air had a shock absorber effect. You could push in the piston but, when released, the compressed air pushed the piston out. The assembly testing was then carried out totally under water, with the valve removed to allow the water to escape from the front of the cylinder, then plugged to create the vacuum chamber. This pull trial produced a similar instantaneous release at around 400 pounds pull force. This was slightly better than past performance.

It was then decided to simulate the proper sized piston and cylinder clearances and o-ring groove geometry with a short piston in the existing cylinder. This new piston style contained a tapered valve seat and a wire spring to ensure proper seating. This piston had to be pounded into the existing cylinder with a mallet. This pull trial produced a similar instantaneous release at around 400 pounds pull force. Next, a new cylinder was built with a threaded plughole to vent the water / air pressure during assembly. This cylinder had o-ring manufacturer specified clearances. The plug was installed after the piston assembly was complete. The short piston with the tapered valve was again used for this trial. The results were a pull force of less than 100 pounds.



### Discussion of results Phase One

In general, the results show that the strength of the components is satisfactory for the forces experienced. The cylinder did not crack and the piston survived any of the tests conducted. The gripping power of the taper static line holder was exceptional. All line attachment points were very strong. However, there are problems with the piston to cylinder sealing capabilities of the system. The critical feature of a timed release was not satisfied. The primary holding power appears to be generated in friction between the piston and cylinder alone. The testing does not point to a discernable cause for this failure mode. However, piston-in-cylinder sealing arrangements are widespread in other industrial applications. There is no reason to expect that this problem is not solvable. Some thoughts on why the sealing may be malfunctioning are: 1) the sealing surfaces are not smooth enough in the prototypes to enable sealing. 2.) The o-ring manufacturer did not understand the application completely when the geometry specifications were provided, etc. This testing was concluded, at this point, due to a lack of funds to pursue alternate hardware configurations.

In summary, after exceeding a certain threshold strain, about 500 lbs, the whale release rapidly slips until failure. We have solved the problems related to rope gripping and the initial threshold. Cost will be around \$5.00 and the device is reusable. We have encountered design problems with the timing component of the release. This component is an o-ring equipped plastic piston with a check valve inserted into a plastic cylinder housing. More testing is needed on cylinder diameter, valve design, o-ring design, and surface preparation to adjust slippage.

### Test Results Phase Two

Additional funding was acquired to continue the development of the whale release. The first problem was to find out why the cylinder seals were not holding. It was determined that the vacuum that was pulling on the assembly would not generate the force required to hold the piston. Too simply look at it, the maximum vacuum pressure that can be achieved is a perfect vacuum, which is 14.696 psi below gage pressure of zero (at sea level). With a piston diameter of 1.5", the maximum achievable force due to the vacuum is:

$$F = P \times A = P \times \pi R^2 = 14.696 \times 3.1416 \times 0.75^2 = 25.97 \text{ lbs}$$

In order to achieve a force of 1000 lbs by the vacuum the diameter of the piston would need to be increased. Using the above equation and solving for R we can determine the radius of the piston required:

$$R = (F \div [P \times \pi])^{1/2} = (1000 \div [14.696 \times 3.1416])^{1/2} = 4.654 \quad D = 2 \times R = 9.3"$$

The piston diameter required would be 9.3" in order to create a force of 1000 lbs.

These calculations led to a major redesign of the whale release. The vacuum chamber concept was changed to a fluid filled compression chamber. This would be totally sealed to prevent outside dirt from clogging the small valve. The custom built valve was changed to an off-the-shelf Vernay rubber flapper-type check valve. These changes required the whale release to grow from 9 inches to twelve inches long due to the added rod on the piston. The cylinder o-rings were replaced with Parker U-pack rod and piston seals; an other off-the-shelf proven technology. Calculated holding force of this unit is well above 2000 lbs.

A test cylinder and piston were constructed to test the u-packing and the rubber check valve. The first compression test was run at about 500 pounds pull applied to the piston. The test failed and the cause was found to be u-packings that were cut during assembly. The rubber flapper valve, or umbrella valve, leaked as well. The cylinder was re-machined with a lead to eliminate any sharp corners and new u-packings installed. The next test, under similar conditions, found the u-packing to work but the umbrella valve continued to leak under pressure. The umbrella valve was removed and a solid plug inserted. A load of 850 lbs was applied and the unit held the load without creeping for the 12 hour test period. However, the cylinder did deform at the end where the load was applied. This was corrected by machining a disk insert to prevent the cylinder distortion.

We next worked on the valve problem with Mr. Jim Bailey at Vernay Laboratories. We decided to stay with the umbrella type valve but increase the diameter of the rubber flapper. We also brought the hole pattern closer to the center of the valve assembly and decreased the hole size to 0.015" diameter. With these changes the valve works well for sealing under high pressure and in returning fluid to reset the whale release.

The key remaining task is to design and size the orifice that will provide the time delay for the whale release. A series of plugs with different size holes will be fabricated for these tests. The hole size will be very small which may require significant problem solving both from an operational and fabrication perspective. Fluid viscosity, which is temperature dependent, may create large variations in the flow rate through the piston orifice. Once the lab testing of this stage is complete an assembled working model will need to be constructed for extensive lab and field tests.

The whale release as envisioned now would be sold as a single unit, assembled out of molded and machined pieces, with no loose components. The whale release unit would be assembled at the point of manufacture. First, the check valve is inserted into a plastic set screw which is then assembled to the piston front. The piston front and cylinder insert are screwed to the cylinder. The rope gripper washer and screw are next inserted into the piston rear and then fastened to the piston front with a 5/8-18 UNF thread. A washer and screw are fastened to the front piston to seal the bleeder line. The fisherman just needs to insert the end of the line into the release. When the release lets go the unit stays with the lobster trap; there is no component or knots on the released line.

### **Recommendations For Future Work**

1. Field test the Chicago grip type messenger: Preliminary test indicate that this type messenger is ready for more extensive field trials in order to further explore the messenger concept. Design issues relate to the type and location of the bottom weak link. There are also operational questions regarding expected loads placed on a buoy line and weak link upon approach and retrieval. On-deck handling of the hook-up and second (hauling) line needs further development.
2. Squid messenger development: A refined and improved version of the squid messenger needs to be fabricated and tested based on what we have learned from the previous prototype. This will require some engineering design work using CAD software as there are many possible permutations of the tentacle/plug hook-up mechanism.
3. Timed whale release: This unit will now require development and testing of the timing orifice. Calculations have been performed to give a theoretical hole size but actual testing of this component will begin shortly. If all works according to plan, another complete prototype should be fabricated by machining for testing. If this prototype proves successful then a tough economic decision needs to be made. This unit is only affordable as a molded plastic construct. The cost of designing and tooling the molds can exceed \$40,000. This project may be a good candidate for an SBIR type grant. NMFS should explore this and other possible funding mechanisms.

# POTENTIAL ENTANGLEMENT POINTS OF LOBSTER GEAR

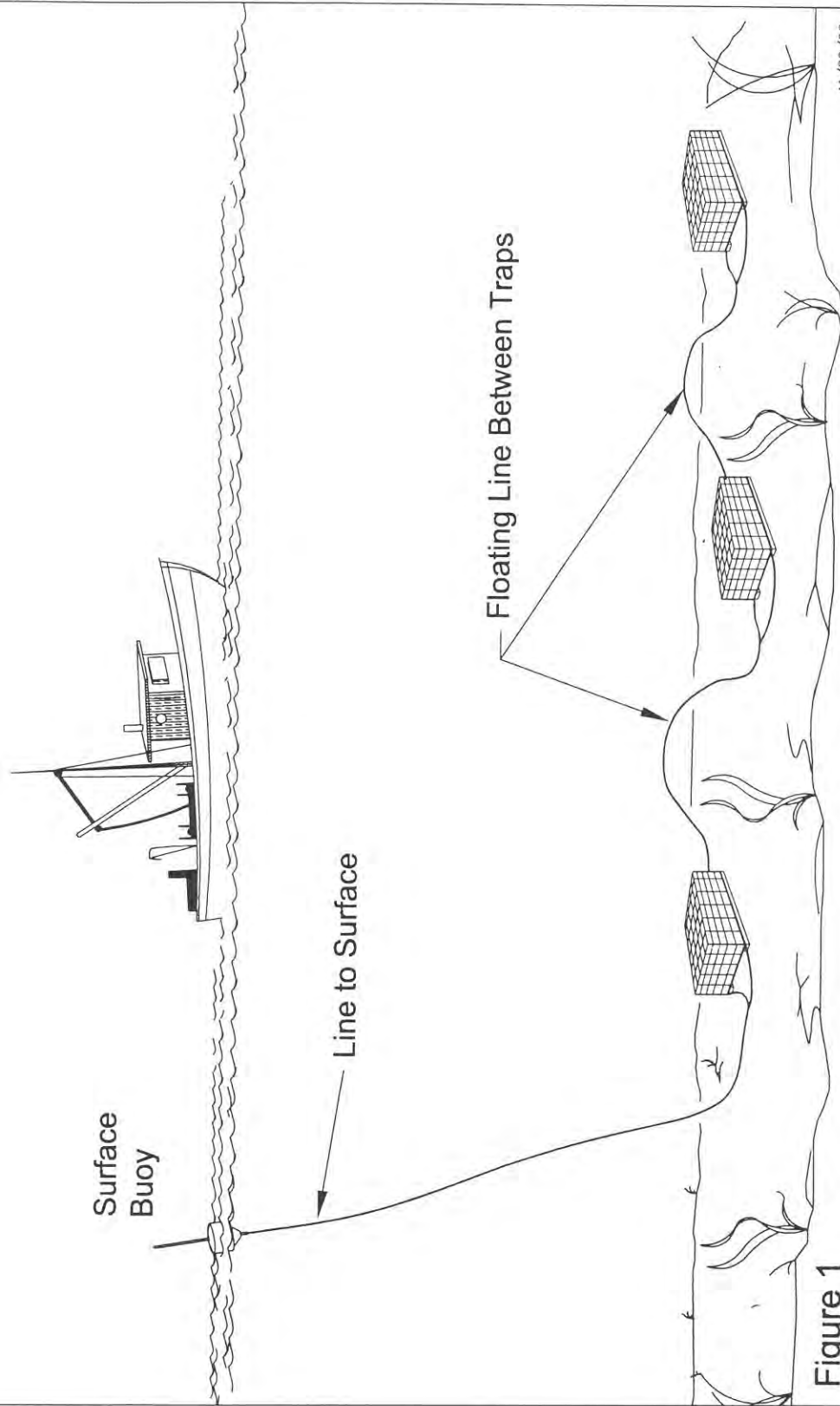
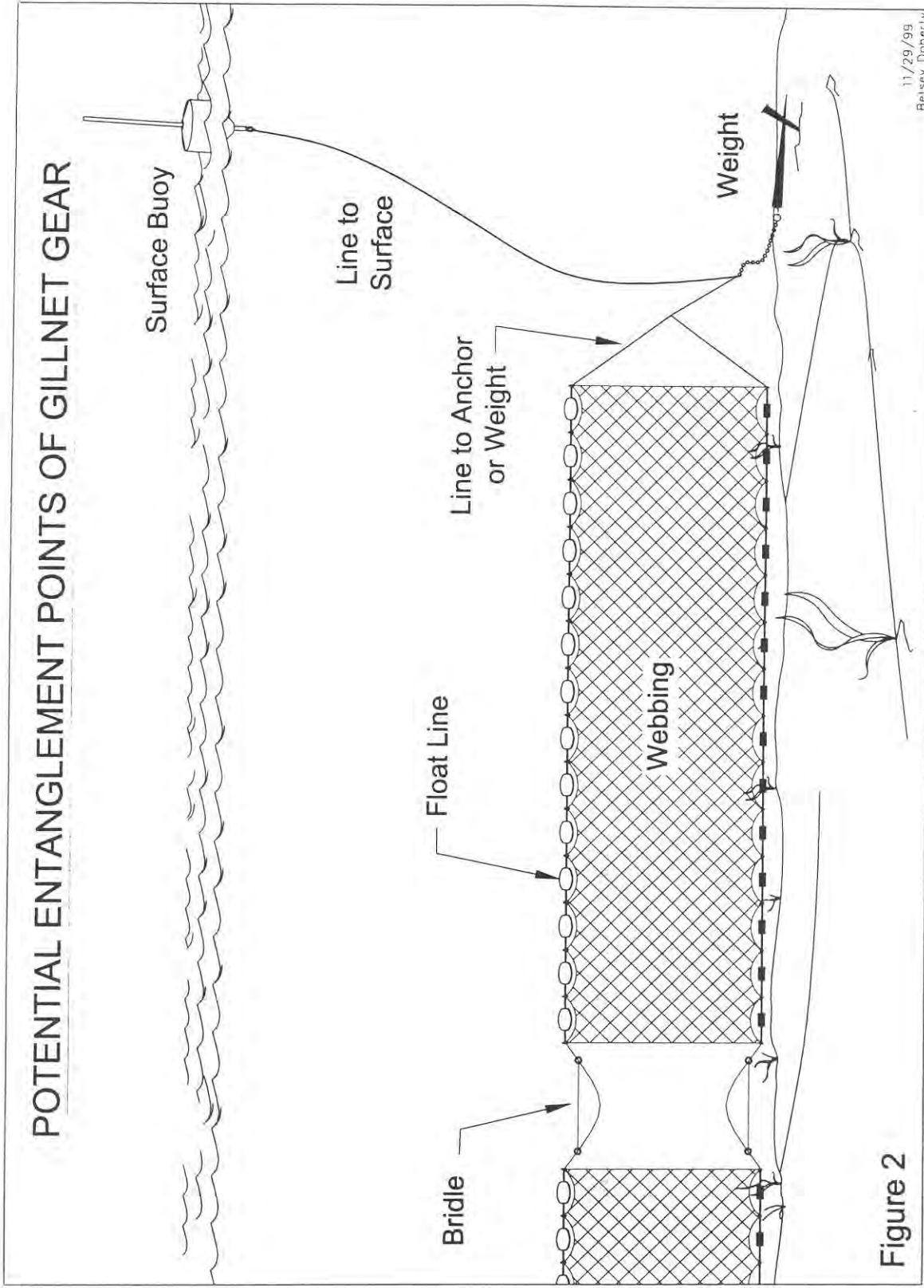

Figure 1

11/29/99  
Betsy Donerly



# POTENTIAL ENTANGLEMENT POINTS OF LARGE WHALES

Insertion  
of Flukes

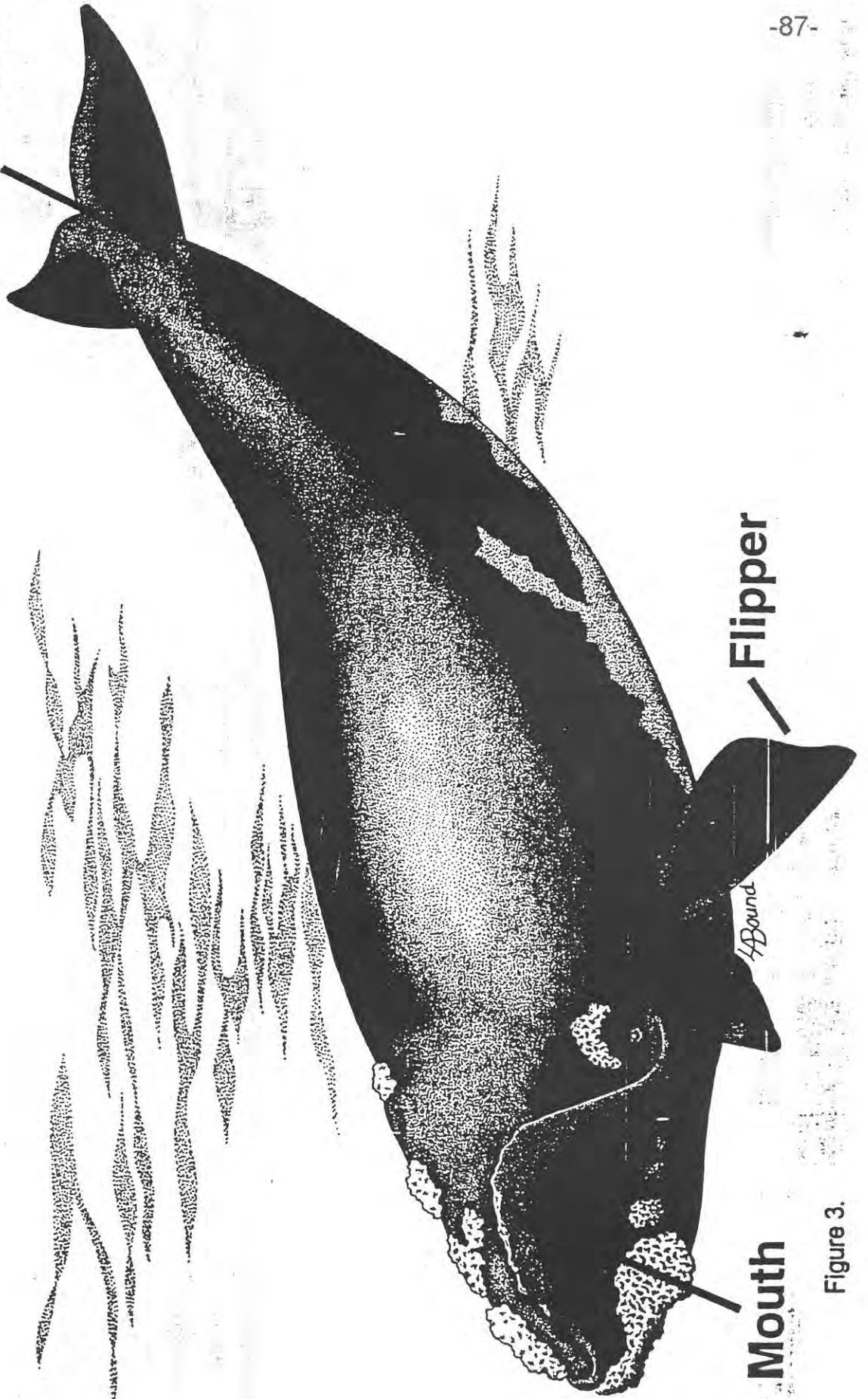

Mouth

Flipper

HBound

Figure 3.

# BREAKAWAY BUOY CONCEPTS

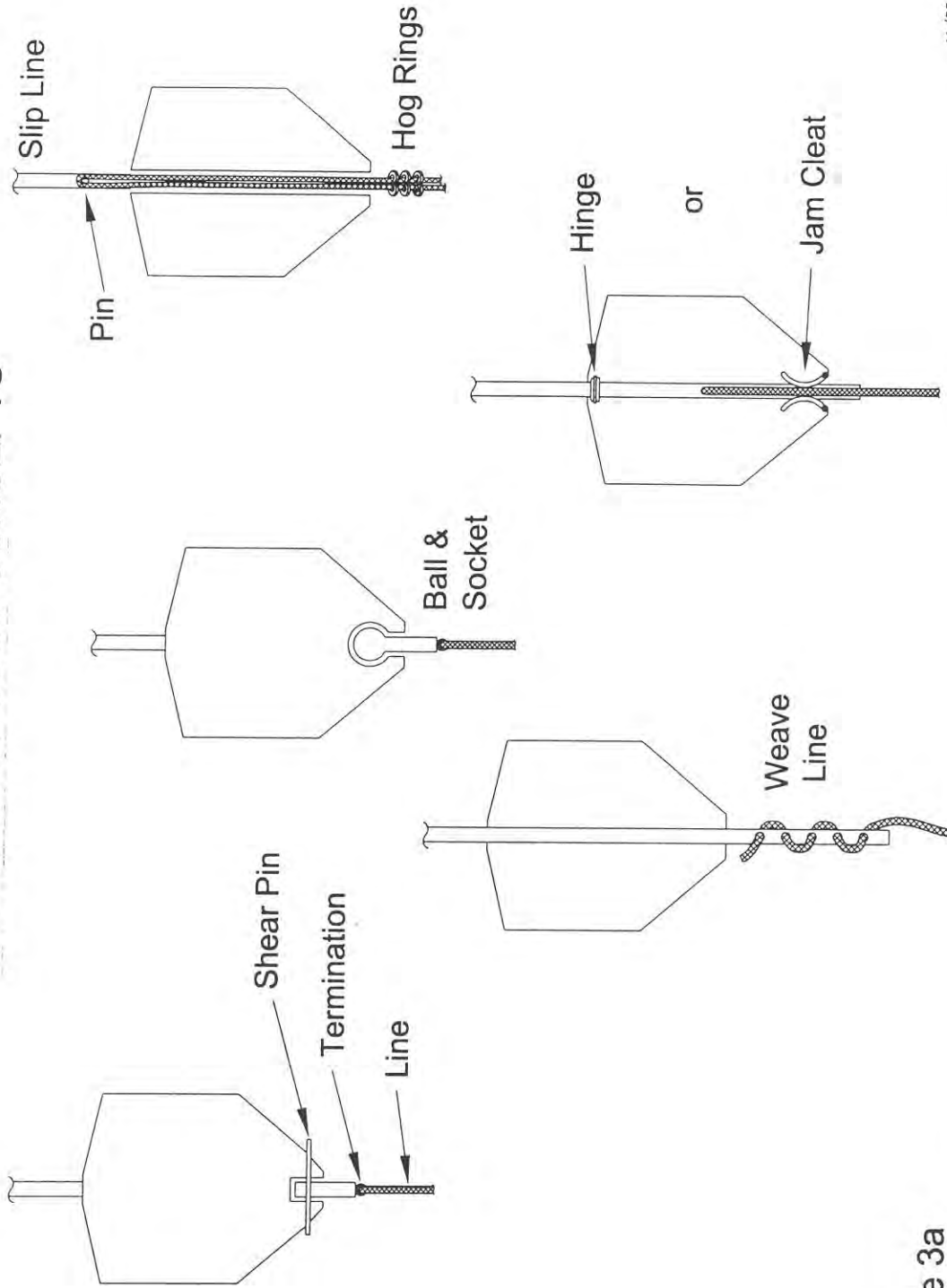

11/29/99  
Betsey Doherty

Figure 3a

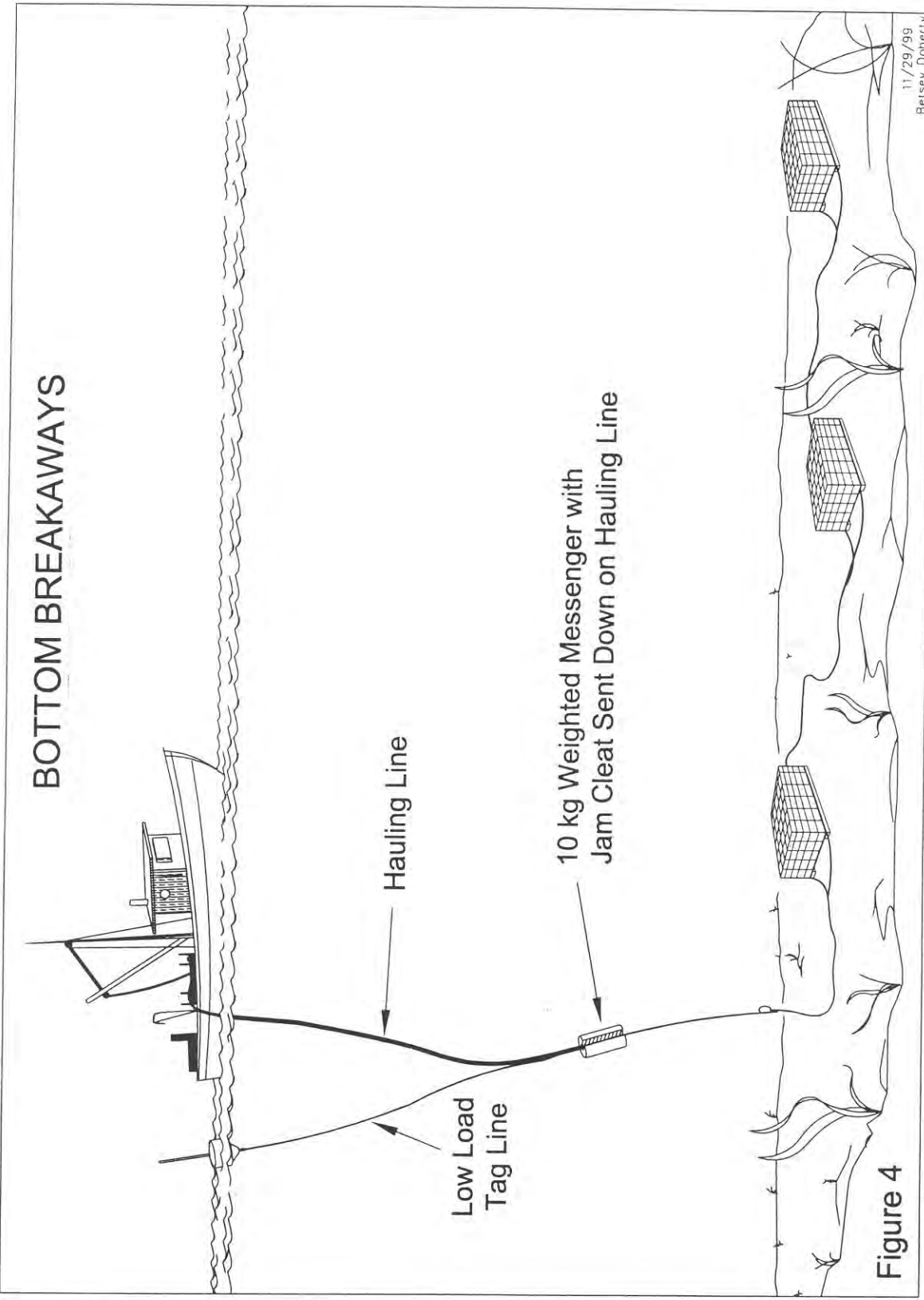
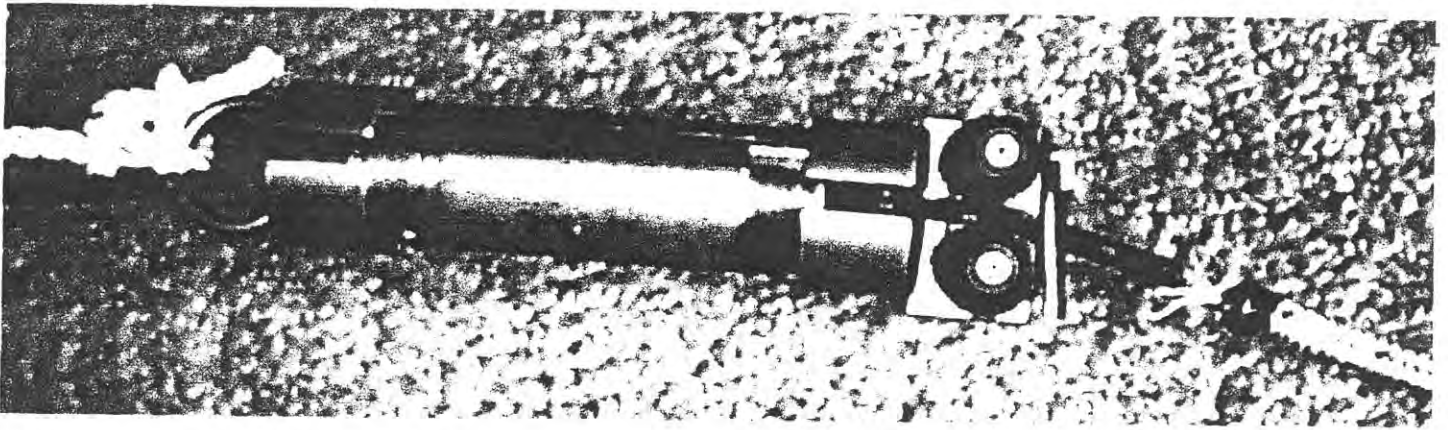

Figure 4

11/29/99  
Betsy Doherty





**FIGURE 5: JAM CLEAT STYLE MESSENGER**

The twisted polyline is fastened by hog rings to the braided pennant.

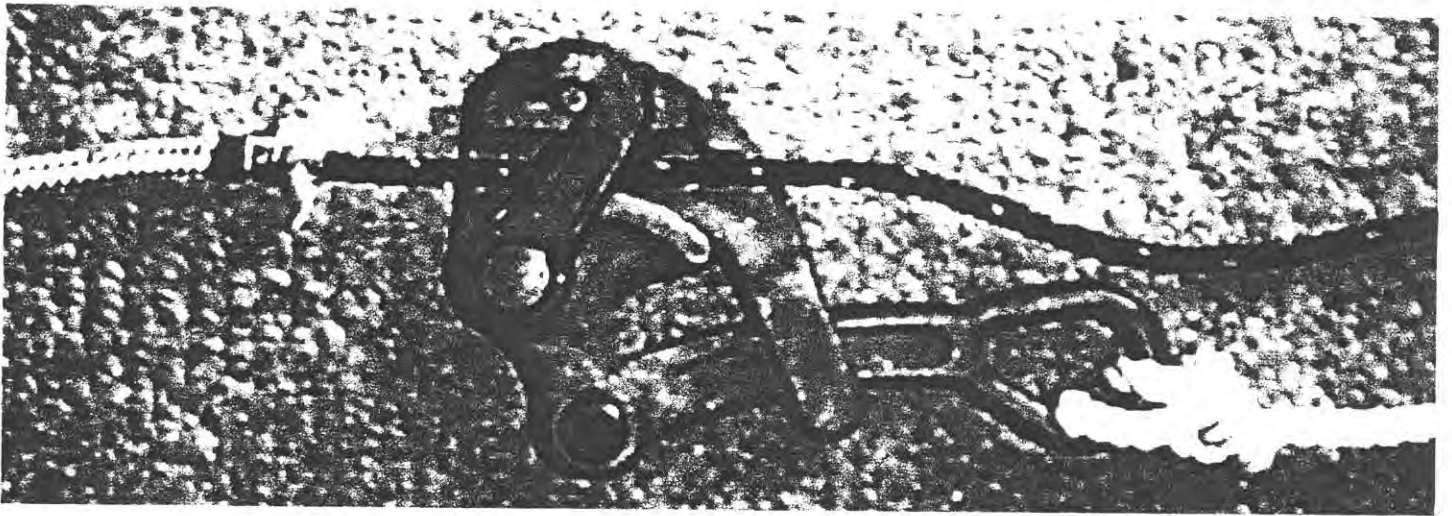

**FIGURE 6: CHICAGO GRIP OPEN POSITION**

The grip is in the open position approaching the hauling pennant.

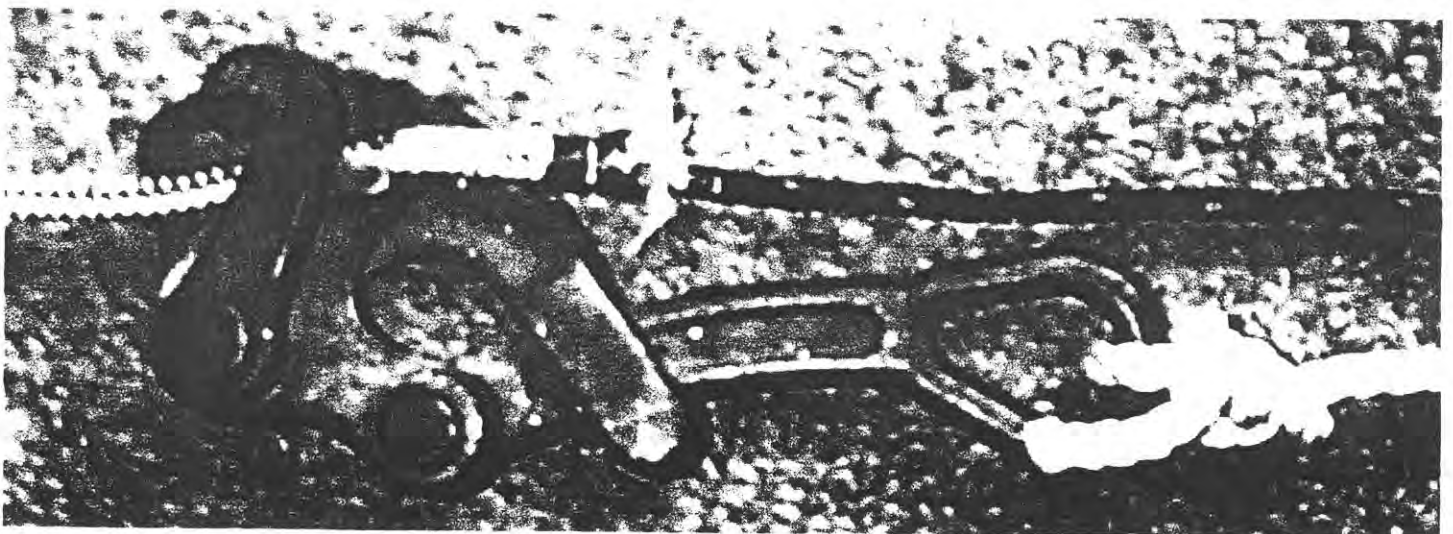

**FIGURE 7: CHICAGO GRIP CLOSED POSITION**

The grip is in the hauling position.

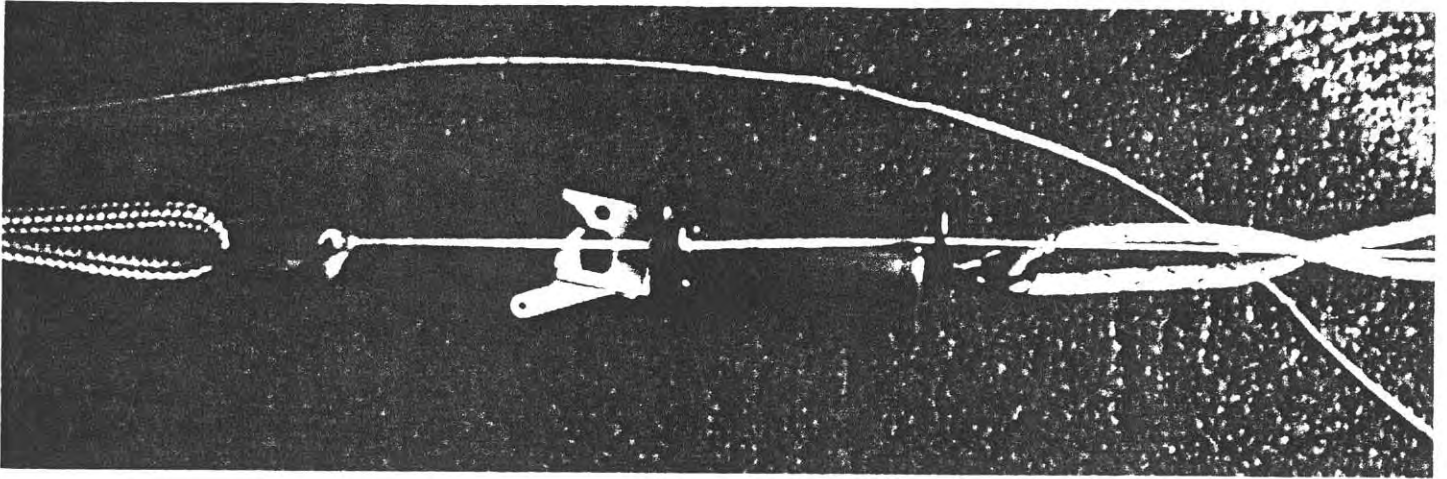

**FIGURE 8: LATCH STYLE MESSENGER**

The messenger in position approaching the hauling pennant ring.

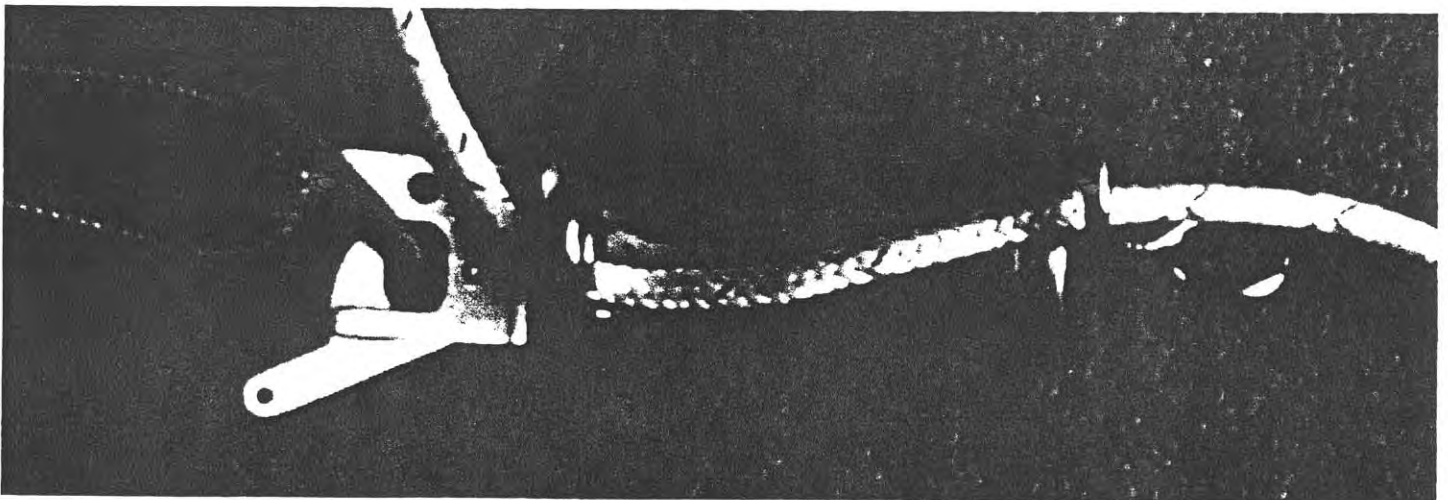

**FIGURE 9: LATCH STYLE MESSENGER**

The messenger in the latched position ready to haul.

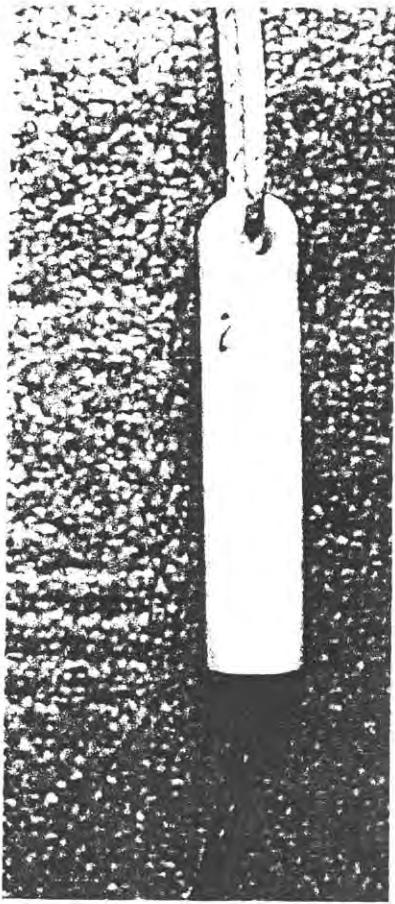

FIGURE 10:  
Fully assembled.

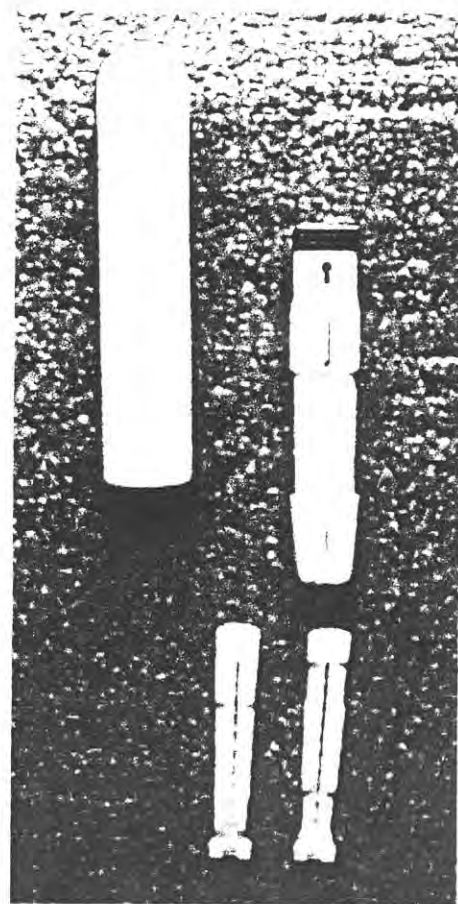
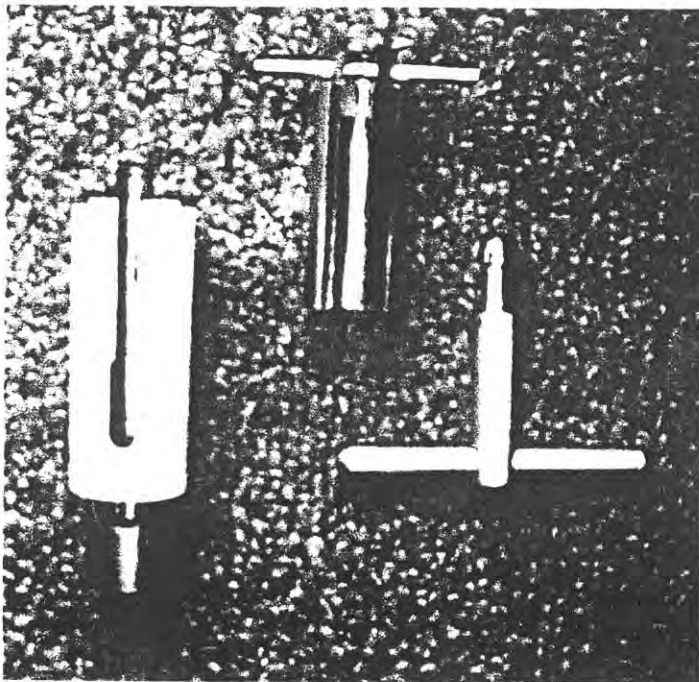

FIGURE 11:  
Major components; housing,  
piston and rope grip halves.



FIGURES 10-12:  
TIMED WHALE RELEASE

**Baleen Tests**

ALL READINGS IN POUNDS

	Right Wh		Blue Whale <i>wet</i>		Blue #2		Blue Intact Jaw		Humpback <i>wet</i>	
	Straight		Straight	90 deg. 45 deg.	Straight	90 deg. 45 deg.	Straight	90 deg. 45 deg.	Straight	90 deg. 45 deg.
3/16" poly			0	0 0						
1/4" poly			0	0 0					11	7
knot			7	2.5 11					17	23
out > in			12							
5/16" EZ haul	10		0.5	0.5 0.5					22	21
knot			10	9.5 9.5					23	40
out > in			40							
5/16" grn poly			1	1 1			1	1 1	16	24
knot			10	11 11	13	15	15	15		
across plate			31		22					
out > in					38			30	24	48
3/8" grn poly			2	2.25 2.75			1.5	6 5.5	18	16
knot			26	20 20	12	23	23	23		31
across plate			45		20					
out > in					49			58	55	43
7/16" ploy-dac	19									
knot - out > in									17	13
5/8" poly-dac			8	9 18			4	9 8.5	26	27
knot			42	22 57	23	39	48			
across plate			82		34					
out > in					67			85	71	149
1-3/16" nylon										
									11	(one side of baleen)
									33	(across @ lg. angle)

# Weak Link & Buoy Line Marking Techniques

November, 21 2000

Gear Research Team  
Protected Resources Division  
NMFS, Northeast Region

## Hog Rings

Tests were run in the laboratory on a variety of ropes using 5/8" hog rings to form an eye with the following results:

5 hog rings forming an eye in 3/8" poly-dac had an average strength of 470 pounds.

7 hog rings forming an eye in 3/8" poly-dac had an average strength of 605 pounds.

7 hog rings forming an eye in 3/8" poly-steel had an average strength of 540 pounds.

7 hog rings forming an eye in 5/16" poly-dac had an average strength of 580 pounds.

No significant variation was noted between wet and dry tests. Also, the length over which the hog rings were distributed ( from 6" to 12") didn't significantly affect the strength.



## Off the Shelf Weak Links

The Modern Mould Sliplink <sup>™</sup> is a knotless system based on the same theory as a jam cleat. In its present configuration its holding strength is 400 pounds.



Plante's Lobster Vents, Inc. is currently developing a swivel that incorporates a weak link. It can be manufactured for different strengths (500, 600, 1100 etc.) as required. They are expected to be available around the first of the year.

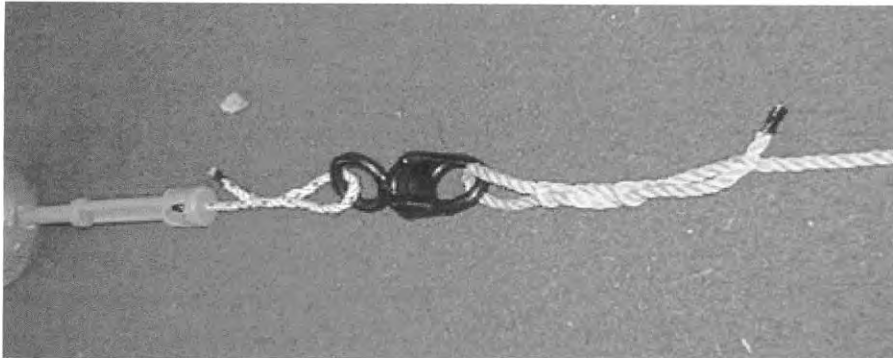

### Higher Strength Weak Links

A weak link technique suitable for higher loads is a spliced jumper. The jumper is selected based on breaking strength data from the manufacturer.

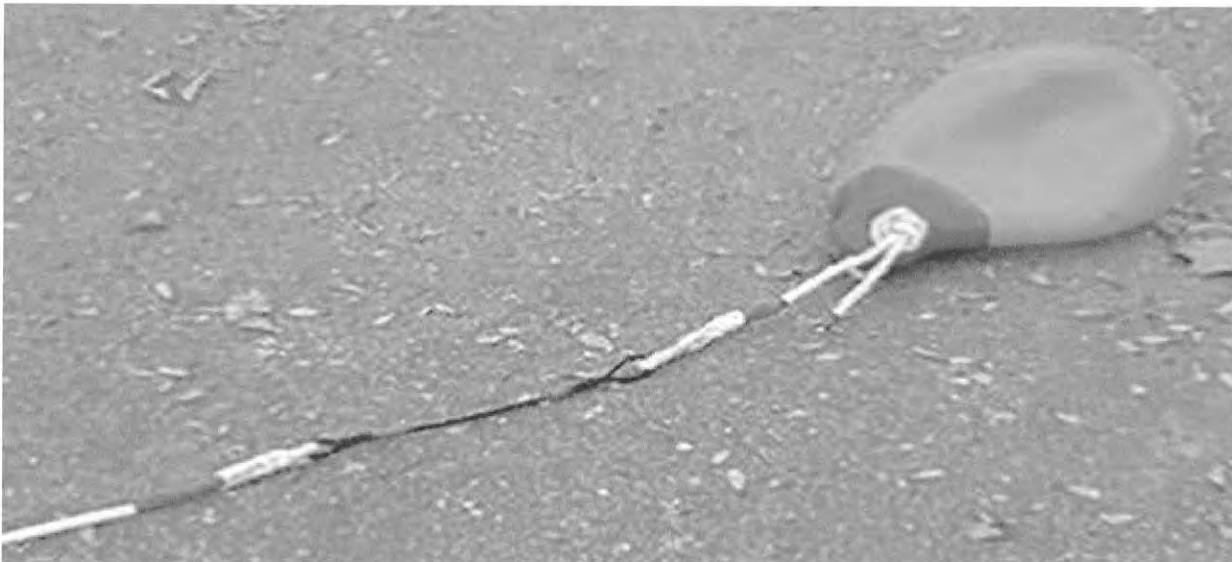

### Buoy Line Marking

Buoy lines can be marked in a variety of ways. Shown below are three simple methods that were tested and found to work satisfactorily under normal conditions. At the top, colored twine is seized around the line and woven between the strands. In the center

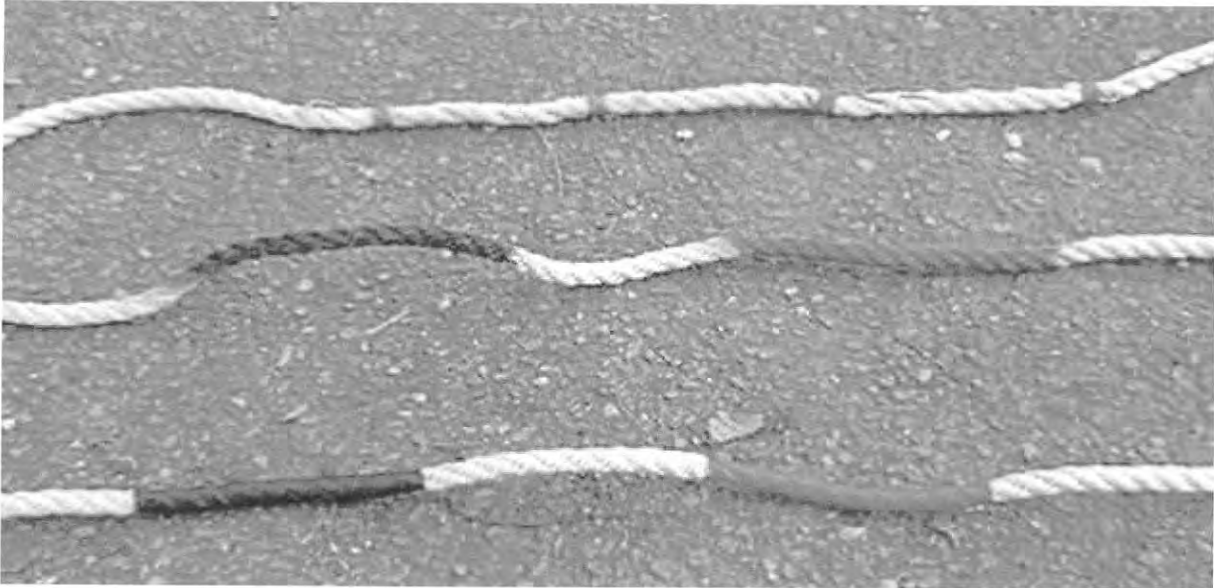

the line was spray painted. This method requires that the rope be dry. At the bottom, colored electrical tape was wrapped in one direction and then back over itself to form two layers.

# Effects of Creep Loading on A Standard Anderson Weak Link

John F. Kenney  
NMFS  
January 2000

A standard 400 pound Anderson weak link<sup>1</sup> was subjected to a static load of 200 pounds for a total of 189 hours (approx. 8 days). Elongation over time is depicted in the graph. The photograph shows the elongation at 144 hours. Subsequently, the elongated link was loaded until it failed. Failure occurred at 390 pounds, or within 5% of samples not subjected to any creep loads.

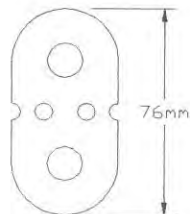
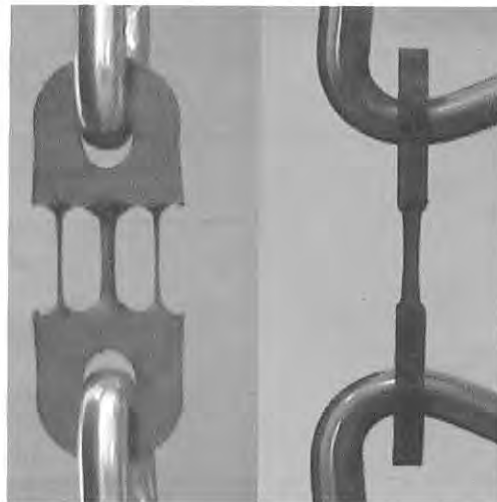
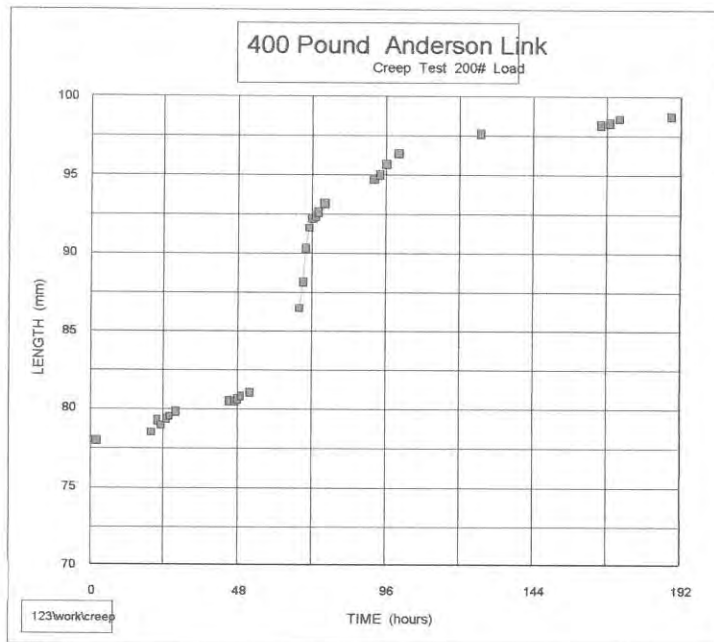

The original overall length of the weak link is 76mm (left). The pictures above show where the elongation occurred.

<sup>1</sup>Peter M. Anderson, The Design, Testing, and Production of Mechanical Weak Links For Fishing Gear, final report, April, 1998.



# Knots & Weak Links - - 1/4" Poly-Dac

NMFS - Kingston, RI

February, 2000

**NOTE:** The results of these tests are for informational purposes. Methods shown should not be interpreted as being in compliance with the weak link requirements of the Large Whale Take Reduction Plan. For accepted weak link techniques, see: <http://www.nero.noaa.gov/whaletrp/plan/index.htm>

Type	Description	Load at Failure (lbs)
In-Line Tests	Full strength	1425
	Overhand knot	730
	Fisherman's knot	905
	2 tucks each end	305
	3 tucks each end	1220
	3 hog rings	105
	5 hog rings	150
	7 hog rings	200
	9 hog rings	270
Eyes	bowline	995
	2 tucks	1345
	3 tucks	1495



Type	Description	Load at Failure (lbs)
Eyes (Cont.)	1 hog ring	100
	2 hog rings	175
	3 hog rings	260
	4 hog rings	295
	5 hog rings	360
Termination at buoy swivel	1 strand with clove hitch & half hitch	460
	2 strand with clove hitch & half hitch	815
Termination	wooden toggle, 3/4" x 3/4", 1/2" hole	580
	wooden toggle, 1" x 1", 1/2" hole	1060

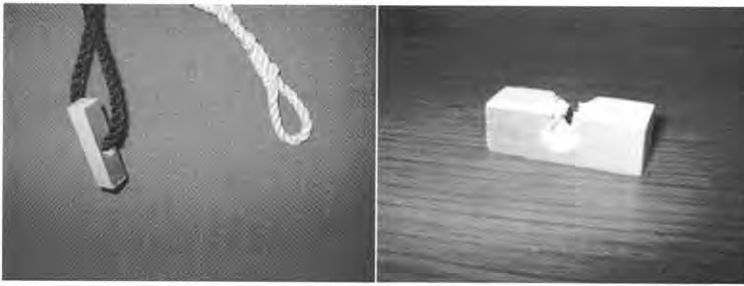
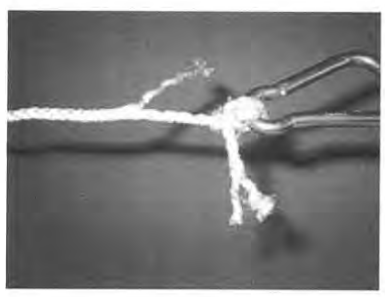
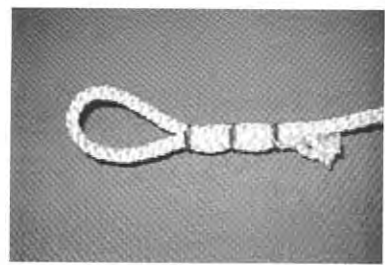

No  
Other types & sizes of line will exhibit different strength characteristics.  
For more information contact:  
John Kenney, 401-294-0443,  
[John.F.Kenney@noaa.gov](mailto:John.F.Kenney@noaa.gov)

**NOTE:** The results of these tests are for informational purposes. Methods shown should not be interpreted as being in compliance with the weak link requirements of the Large Whale Take Reduction Plan. For accepted weak link techniques, see: <http://www.nero.noaa.gov/whaletrp/plan/index.htm>

TESTS OF 'LOCKTITE' LINE -- MFG. BY NEOCORP, PAWTUCKET, RI

Tests were NOT conducted in accordance with ASTM or Cordage Institute standards and should be used for reference only

SIZE	TEST	NUMBER OF SAMPLES TESTED	FAILURE OCCURRED AT:	MAXIMUM VALUE RECORDED	MINIMUM VALUE RECORDED	AVERAGE
#7	UNALTERED	8	FIXTURE	761	725	744
	OVERHAND KNOT	3	KNOT	456	444	448
	FISHERMAN'S KNOT	5	KNOT	459	400	429
#8	UNALTERED	3	FIXTURE	1332	1292	1309
	OVERHAND KNOT	6	KNOT	833	718	775
	FISHERMAN'S KNOT	8	KNOT	880	640	780
#9	UNALTERED	4	FIXTURE	802	766	789
	OVERHAND KNOT	5	KNOT	629	546	593
	FISHERMAN'S KNOT	7	KNOT	567	489	539
#10	UNALTERED	2	FIXTURE	1561	1487	1524
	OVERHAND KNOT	5	KNOT	925	806	870
	FISHERMAN'S KNOT	5	KNOT	876	781	828

TESTS CONDUCTED BY J. KENNEY / NMFS 12 & 13 MAY 1998

**NOTE:**

The ultimate breaking strength of the line would be slightly higher than the recorded values for the "unaltered" tests because failure occurred at either the top or the bottom attachment fixture.

# FINAL REPORT

## Estimation of the Tractive Force for the Northern Right Whale (*Eubalaena glacialis*)

Alexander Fridman, David Williams,  
James Guimond, Joseph DeAlteris

Department of Fisheries  
University of Rhode Island  
Kingston, RI 02881  
30 December 1997

### Abstract

Several deaths of Northern right whales (*Eubalaena glacialis*) in the Northwest Atlantic have been attributed to entanglement in fixed fishing gear. Estimates of the tractive force of large whales were developed to better understand the interaction between whales and fixed fishing gear. To facilitate these calculations, information on the swimming kinematics of other marine mammals was examined. Several models of the propulsive forces generated by large whales based on drag, size, and swimming speed were evaluated. Maximum propulsive force estimates for the Northern right whale ranged from 211 kg (465 lbs) for 4 m whales to 4,282 kg (9,440 lbs) for 18 m whales, at 10.0 m/s (20 knots). Maximum estimates of tractive force determined by the method of Fridman (1973), ranged from 61 kg (135 lbs) to 3161 kg (6969 lbs) for the same species and size range. A minimum tractive force estimate, based upon the resistance of a towed vessel and gear during a disentanglement operation of a 12 m Northern right whale, was comparable to the theoretically derived estimates.

## Introduction

### *Background*

The Northern right whale is one of the most endangered mammals in the world. The maximum population size of Northern right whales is estimated to have been 80,000 individuals (McCaffrey 1997, Schiele 1997). From the mid-sixteenth century to the mid-eighteenth century right whales were hunted to near extinction (McCaffrey 1997). Whalers identified these whales as the 'right' whale to harvest, because the whales floated once they were killed, making them easy to bring aboard the vessel, given the harvesting equipment of the time (McCaffrey 1997). Two additional centuries of moderate, yet constant whaling further reduced populations to critically low levels. By 1935 right whale populations were so low, that the north Atlantic population numbered just a few hundred (Waring *et al* 1997).

In 1937 the International Whaling Commission instituted measures to protect the right whale from commercial whaling, yet right whale populations have not recovered (McCaffrey 1997). By 1973, the Endangered Species Act and Marine Mammal Protection Act identified the right whale as a critically endangered species (Beach 1997). Twenty-five more years passed and still the right whale population continues to decline (Beach 1997, Rogers 1997, Waring *et al* 1997).

In 1994 the reauthorized Marine Mammal Protection Act (MMPA) initiated a proactive process designed to reduce the number of marine mammals caught, incidental to commercial fishing, to acceptable levels (Beach 1997, Rogers 1997, Waring *et al* 1997). The MMPA required the National Marine Fisheries Service (NMFS) develop a

two-stage process to reduce the number of marine mammal mortalities caused by humans. The first stage addressed mortality resulting from fishing gear entanglement (Beach 1997). The second stage involved an expanded disentanglement effort, this was done by augmenting surveillance efforts (Beach 1997).

The National Marine Fisheries Service responded to the MMPA by initiating the Atlantic Large Whale Take Reduction Plan (ALWTRP) (Rogers 1997, Waring *et al* 1997). The goal of this plan was to, "reduce the impact of fishing interactions on the most critical species, the right whale, by ensuring that gear regulated by this plan is either removed or significantly restricted in the three right whale critical habitats found in United States waters: Cape Cod Bay, Great South Channel, and the Georgia-Florida border region in the southeast (Beach 1997)." The ALWTRP is intended to be the beginning of a series of management measures developed to meet the MMPA goal of a zero rate of human related right whale mortality by the year 2001 (Beach 1997, Rogers 1997, Waring *et al* 1997).

In 1997, an estimated 300 individuals remain in the Western North Atlantic (Waring *et al* 1997). The fate of the right whale remains unclear, because scientists are unsure whether the right whale population has dropped below the required size to maintain a healthy and productive gene pool (McCaffrey 1997). If in fact the numbers are below the minimum sustainable point, interbreeding will eventually weaken the gene pool, possibly forcing the species into extinction.

The extremely low number of right whales left today is alarming; especially after 60 years of protection from whaling (McCaffrey 1997). Scientists have identified why,

despite these protective measures, no significant recovery has occurred. Human interference has been pinpointed as the major factor preventing the whale's recovery (Beach 1997).

The number of right whale deaths during the period from 1970-1993 is estimated at 30 (Waring *et al* 1997). Anthropogenic related deaths represent 1/3 of all right whale mortalities during this period, with eight mortalities resulting from ship collisions and two from fishing gear impacts (Waring *et al* 1997). More recent estimates (1991-1995) have revealed an approximate take of 0.4 individuals annually by entanglement in fishing gear, with ship strikes causing 1.4 deaths per year (Waring *et al* 1997). An additional 0.7 individuals per year are also killed from other fishery related impacts. The total amount of right whales killed each year by human activities is about 2.5 individuals, which is well above the levels set by the 1994 Amendments to the MMPA (Beach 1997).

### *Objective*

To better understand whale entanglement in fishing gear, the mechanisms of entanglement must first be understood. Current evidence indicates lobster traps and gillnets as the gear that the whales become entangled (Beach 1997, Schiele 1997a, McCaffrey 1997, Rogers 1997, Waring *et al* 1997). This is because both these fishing gears utilize vertical lines to the surface in order to mark them and for retrieval. While the exact pattern of entanglement is not known, it appears that while the gear is left fishing unattended, the whales encounter the vertical lines with either flukes extended or mouths open for feeding. As the whale contacts the line, the rope slides past the flukes or through

the mouth, until a knot or buoy snags on the whale and results in entanglement (McCaffrey 1997).

A possible solution to the entanglement issue is the use of a weak link, or breakaway device on the vertical surface line. This type of device would release upon the application of sufficient force, thus breaking the rope free of the gear itself, and ideally breaking the rope free of the whale (Rogers 1997, McCaffrey 1997, Waring *et al* 1997).

The objective of this study was to develop methodologies to estimate the maximum tractive force capable of being generated by a Northern right whale. Maximum propulsive force may be estimated based on hydrodynamic resistance of a whale swimming at maximum speed. Similarity analysis between different cetacean may also be used to estimate the maximum tractive force. Finally data collected on objects towed by right whales during rescues operations may be analyzed to determine the minimizing tractive force capable of being generated by right whales. Knowledge of the forces involved while swimming will be helpful in guiding NMFS through the gear modification process, thereby minimizing the likelihood and impacts of entanglement.

## **Literature Review**

### *Propulsion*

There are two theories of whale propulsion. The first theory is based on the force developed by a vertically oscillating propeller (Aleyev 1977, Bose & Lien 1989, Bose *et al* 1990, Curren 1994). The amount of propulsive force that can be developed correlates with the frequency and amplitude of the fluke's beat in a viscous fluid. Propulsive force is dependent upon the size of the fluke, fluke sweep angle, aspect ratio, and chord and



span flexibility, however the relationship between these factors and propulsive force efficiency is unclear (Aleyev 1977, Bose & Lien 1989, Bose *et al* 1990, Curren 1994).

The second theory of propulsion is based on the animal's body bending, similar to a snake's movement, pushing the whale forward thru the water. The bending is produced by an alternate rhythmical muscular contraction in the upper and lower parts of the whale's body (Shuleikin 1953). This produces a wave-like motion from the head to the tail. Forward motion results from transverse oscillation, a continual movement of a 'hard wave', with energy transferred into the water. As evidence of this theory, a whale with seriously damaged fluke, is still able to maintain high swimming speeds for a long period of time (Томилин 1969). During each oscillation of the whales body, the relation between maximal and minimal pushing force, changes with different phases of motion. The transverse parastolic forces are moving the whale's body about its horizontal axis. The combination of these factors make calculation of the whales propulsive force extremely difficult.

Using these approaches, propulsion theories have been developed based on the solutions of hydrodynamic problems occurring in the fields of naval architecture (Aleyev 1977, Huntley *et al* 1987). However, these models are based on many variables and assumptions. This leads to the suspicion that we still do not know how a whale swims; and suggests that the solution may be found within experimental hydrodynamics.

*Hydrodynamics*

Several swimming studies have been conducted on small cetaceans (Curren 1994, Hui 1987, Huntley *et al* 1987, Lang 1966). Large and small marine mammals can be compared using the theory of dynamic similarity which predicts the flow around streamlined bodies of different size or swimming speed (Huntley *et al* 1987). Dynamic similarity also known as engineering similarity analysis is most frequently used to evaluate ship and submarine hull designs or fishing gear performance by using physical models (Fridman 1973, Huntley *et al* 1987).

To estimate the tractive force of a large whale, the drag of the whale must be determined. With other conditions equal, hydrodynamic drag is dependent on the Reynolds number (Aleyev 1977, Fridman 1973, Lang 1966). The Reynolds number represents a streamlined body's resistance or drag in a fluid, depending on the fluids inertia (Aleyev 1977, Fridman 1973). Reynolds number ( $R_e$ ) is represented by the following equation:

$$R_e = \frac{lU}{\nu} \quad (1)$$

where  $l$  is the absolute length of the animals body,  $U$  is the velocity of the swimming animal, and  $\nu$  is the kinematic viscosity of water (Aleyev 1977). The data on marine mammal drag is limited because of the confusing results and unfounded speculation surrounding what is known as the "skin effect" (Lang 1966, Hui 1987, Kramer 1960). The "skin effect" is the suggestion that certain swimming animals can control drag by manipulating their skin. The "skin effect" is alleged to decrease turbulent flow at the boundary layer (by minimizing the formation of vortices), allowing some degree of

laminar flow (Lang 1966, Kramer 1960). To determine the magnitude of the “skin effect” on drag several studies were examined. A study of a Pacific white-striped dolphin, determined that the dolphin possessed some mechanism to reduce the drag on its body. A laminar flow of 20% was estimated for the dolphin. While this estimate of laminar flow was not thoroughly understood, it was based on a parity between power and drag. That is, either the dolphin has significantly more power than expected, or the dolphins drag had been reduced by the “skin effect” allowing laminar flow, which increased hydrodynamic efficiency (Lang 1966).

To reproduce this on a larger scale, Lang (1966) estimated swimming power of the killer whale (*Orcinus orca*). Measurements of killer whale swimming speeds were based on reported swimming speeds and the duration these speeds were maintained. It was reported that a 4.6 m-7.3m (15-24 ft length) killer whale approached a ship at 15 m/s (30 knots), and then swam around it for 20 minutes, at speeds in excess of the ship’s 10 m/s (20.6 knots) forward advance (Lang 1966). If this information is accurate, it would suggest significant laminar flow of 70%, at a Reynolds number of  $4 \times 10^7$  (Lang 1966). If laminar flow were not present in this case, it must be estimated that the killer whale had three times the previously reported power (Lang 1966).

Although the killer whale is much larger than the typical dolphin, the validity of these estimates in comparison to the much larger whales that are the subject of this study is in question. By comparison it has been hypothesized that the effects of laminar flow on the much larger right whale would be quite small in comparison to laminar flow of the killer whale. This is because laminar flow is most helpful in reducing drag when turbulent flow and boundary layer destabilization is highest. Therefore understanding the

effects of speed on drag must be examined. Drag in a viscous fluid is ultimately dependent upon the speed of travel through the fluid, and is proportional to the square of the velocity when the Reynolds number is constant (Aleyev 1977, Fridman 1973). The swimming speed of the right whale is believed to be much less than that of the *orca* (Kenney 1997). Therefore the effect of turbulent flow drag on the right whale would likely be a much smaller percentage in relation to total drag, and thus laminar flow is not nearly as critical for right whales to maintain sufficient thrust to drag ratio.

Typical sustained swimming speeds of large whales range from 1-2.5 m/s (2-5 knots) (Bose and Lien 1989, Kenney *pers comm*). These values were obtained over long periods of time, typically during the course of the whales' migration based on measurements made using satellite tags (Bose and Lien 1989, Anonymous 1997b, Schiele 1997b, Jones 1997). Maximum swimming speeds were found to be approximately 4-6 m/s (8-12 knots) (Kenney 1997, Bose and Lien 1989). These values were obtained from first hand accounts, as well as the hypothesis that whales of the same family would have related swimming speeds. Typical feeding speeds for the right whale are 0.5-1.5 m/s (1-3 knots) (Kenney 1997).

Aleyev (1977) conducted hydrodynamic experiments for a number of species, using scale models, and compared his findings with live specimens, including estimates of a drag coefficient for right whales. Omura (1957, 1958) and Omura *et al* (1969) reported detailed morphological measurements and weights of 13 right whales that were captured during the period between 1958 and 1969. From these measurements it is possible to develop estimates of the Reynolds number and coefficient of drag, for the reported lengths.

Anecdotal information on the towing power of the right whale was found. This information came from a whale rescue event by the Center for Coastal Studies in Provincetown, MA. During the disentanglement of a 13m (43 ft) 35 mton (38.6 t) right whale, the rescuers attempted to fatigue the whale, so as to allow them to approach. They added excess drag to the whale to slow it. This included an 8 foot sea anchor, 5 Norwegian balls, and an inflatable boat. Additionally, the rescuers tied the 12.8 m (42 ft) fishing vessel "Miss Fitz" to the whale, and for one hour the vessel and gear were towed by the whale at a speed of 4.5 m/s (9 knots) (speed recorded by a global positioning system (GPS) receiver). However, during this encounter there was a 2.5 m/s (5 knot) "fair tide", resulting in the whale's forward progress at 2 m/s (4 knots) in relation to the water. During this period of time the "Miss Fitz's" engines were briefly reversed (at 900 rpm), and further slowed the whale to 3.5 m/s (7 knots), thereby reducing forward headway to 1 m/s (2 knots) in relation to the water. On two occasions during the rescue, the whale parted a 1.25 cm (½") polydacron rope with an estimated breaking strength of 1800 kg (400 lbs.). Finally with the additional drag, the whale's forward progress was slowed sufficiently, allowing the rescuers to cut the gear free (*Our pers comm*).

Observations of right whale behavior can be used to develop a basis for estimates of tractive force. However, additional factors may be required for consideration. Most important among these is the amount of pain the right whale feels during an encounter with fishing gear lines. A study conducted by the New England Aquarium in 1991 involved the use of a dart gun, with the dart tethered to the gun in order to retrieve skin biopsy samples from the whales. The procedure involved approaching a right whale on a boat and shooting a dart into the back of the whale to retrieve a biopsy sample. It was

found that some 20% of the whales that were darted demonstrated a significant change in behavior. Behavioral changes were documented by a dive, a tail flick, or lobtailing, (Brown *et al* 1991). Eighty percent, however, showed little or no reaction to the sampling. This suggests the need to develop a “pain hypothesis”, and raises the question, “What if the whale is capable of breaking the line and chooses not to do so?” Several explanations can be rendered for the minimal reaction of the whales. First, the whales exhibit no significant reaction to the entanglement, thereby not applying the amount of force necessary to break the lines. A second possible hypothesis can be formed by examining the whale’s movement after an entanglement occurs. What do the whales do? Do they continue swimming in typical form, or perhaps do they react by rolling to escape entanglement. If, in fact, the whales do roll to escape, we can further hypothesize that they may be moving in a way such that they are unable to apply their maximum power to the entangling lines.

## Methods

*Part 1. Estimation of the propulsive force developed by right whales of different length when freely swimming at different speeds.*

The propulsive force of freely swimming right whales may be estimated by the resistance of their bodies in water. The force applied by the swimming whale is equal to the resistance of the water on the whale. The resistance of a body moving through a fluid may be calculated by the following formula:

$$R = \frac{C_{DP} \rho S V^2}{2} \quad (2)$$

Where  $C_{DP}$  is a drag coefficient which is dependent upon the shape of the body and corresponding Reynolds number,  $\rho$  is the density of the fluid,  $S$  is the surface area of the body in question, and  $V$  is the velocity at which the body is traveling through the fluid.

Aleyev (1977), through the use of scale models, determined the value of  $C_{DP}$  for a 14.0 m right whale, *Eubalaena glacialis*, to be 0.005. For our calculations, this coefficient was assumed to be constant over all sizes of whales at all speeds and to be independent of Reynolds number. The density of salt water,  $1025 \text{ kg/m}^3$  was used for  $\rho$ . The surface area of whales of a known length was assumed to be the same as that of a corresponding ellipsoid with circular cross-sections and thickness ratio,  $U$ . Where  $U$  was determined by the maximum diameter ( $D$ ) and total length ( $L_c$ ):

$$U = \frac{D}{L_c} \quad (3)$$

For right whales,  $U=0.201$  was determined from the average of values reported by Omura (1969). Measurements of the depth of the body at the umbilicus of 13 Pacific right whales were used for  $D$ . Omura *et al* (1969) states that there is no morphological difference between the measurements of right whales of the Atlantic and Pacific stocks. Lengths used for calculations ranged from 4.0 m to 18.0 m (13-59 ft). An ellipse of corresponding thickness ratio,  $U$ , is easily superimposed upon a profile of a right whale (Figure 1). Right whales generally travel long distances at speeds of 1 to 3 m/s (2-6 knots), and have been reported to feed at speeds of up to 5 m/s (10 knots) (Mate *et al* 1992, Kenney *pers comm*). Burst speeds of many nektonic organisms may be nine to ten times as great as normal cruising speed (Aleyev 1977). Therefore a range of velocities from 0 m/s to 10 m/s (0-20 knots) were used in these calculations.

*Part 2. Estimation of maximum tractive force based on similarity equations.*

Fridman (1973) developed a method for calculating the maximum tractive ( $R_{\max}$ ) force of a fish or marine mammal. This calculation utilizes the length ( $L$ ) and weight of the animal ( $P$ ) combined with a factor  $X$  which is a function of the resistance coefficient, the whale's maximum speed, the block coefficient of a whale's body, and the specific weight of the animal.

$$R_{\max} = XPL^{\frac{-1}{3}} \quad (4)$$

Shuleikin (1953) conducted tests on the maximum tractive force of a dolphin. The data from these tests were used to estimate  $X=0.9$  for this dolphin (Fridman 1973).

Furthermore, it is assumed that this coefficient is also appropriate for right whales and is



constant for animals of all sizes and swimming speeds, therefore is independent of Reynolds number. Lengths used in calculations ranged from 4.0-18.0 m (13-59 feet). The weight of a right whale of a given length was determined by reevaluating corresponding data for 20 right whales (Omura 1969). Non-linear least squares regression was used to obtain parameter estimates for this relationship.

*Part 3. Estimation of the resistance of objects towed by right whales during disentanglement and rescue operations.*

A rescue crew from the Center for Coastal Studies attached various objects to a swimming right whale in an attempt to slow it down sufficiently to cut away entangled lines. The resistance of these objects was calculated, then combined with the whales resistance to give some indication of the whale's ability to generate force. Resistance of individual objects were determined by equation 2. Resistance was estimated at reported towing speeds of 1.0 m/s (2 knots) and 2.0 m/s (4 knots).

## Results

### *Part 1. Estimation of the propulsive force developed by right whales of different length when freely swimming at different speeds.*

The resistance forces for freely swimming right whales increased, exponentially with speed (Tables 1a and 1b, and Figures 2a and 2b). For small whales, 4.0 m to 8.0 m (13-26 ft), forces ranged from less than 10 kg (23 lbs) at swimming speeds of 1.0 m/s (2 knots) to 846 kg (1866 lbs) at 10 m/s (20 knots) swimming speeds. Larger whales experienced similar resistance forces at 1.0 m/s (2 knots), <50 kg (112 lbs). The force required by these larger whales to travel at speeds of 10 m/s (20 knots) was substantially greater up to 4283 kg (9442 lbs).

### *Part 2. Estimation of maximum tractive force based on similarity equations.*

In order to evaluate the maximum tractive force of right whales by the method of Fridman (1973) it was necessary to evaluate the weight (mton) length (m) relationship. Non-linear least squares regression produced parameter estimates a and b equal to 0.015 and 3.003 respectively, where  $W=aL^b$ . The sum of squared residuals for the model fit was 1598 with an  $R^2=0.99$  (Figure 3). These parameter estimates differ slightly from those reported by Omura, who used linear regression on a logarithmic transformation of the data. The value of parameter b confirms the assumption that right whales of different size are geometrically similar. Estimates of the maximum tractive force for right whales ranged from 61 kg (135 lbs) for 4.0 m (13 ft) individuals to 3131 kg (6902 lbs) for 18.0 m (59 ft) whales (Figure 4a and 4b).

*Part 3. Estimation of the resistance of objects towed by right whales during entanglement and rescue operations.*

The resistance of objects towed by a 12.8 m (42 ft) right whale during a disentanglement operation (previously described in introduction) were calculated at reported towing speeds of 1 m/s (2 knots) and 2 m/s (4 knots). Estimates of resistance of each object are presented in Table 2a and 2b. Norwegian balls were approximately 0.5 m (1.6 ft) in diameter with a drag coefficient assumed to be 0.01, the 2.4 m (8 ft) sea anchor was assumed to have a drag coefficient of 0.02. Hull measurements were obtained for the fishing vessel Miss Fitz from the National Marine Fisheries Service boat registry. The resistance of the vessel was calculated with a drag coefficient of 0.004. In order to estimate the capacity of the vessel to exert force in reverse, the following values were used. The horsepower (hp) of the boat was 380; the engine was placed in reverse at 900 rpms, which is approximately 100 hp (Fridman 1973, Our *pers comm*). One horsepower corresponds to approximately 10 kg (22 lbs) of force, suggesting that the force applied in reverse for this vessel during this instance was 1000 kg (2204 lbs). Total tractive force developed by the whale is the sum of resistance of vessel and gear combined with resistance of the freely swimming whale at the corresponding speeds. Total resistance for this situation was 269 kg (593 lbs) at 2 m/s (4 knots), 1075 kg (2369 lbs) at 1 m/s (2 knots).

Comparison of the results of these three methods reveals similar estimations of right whale tractive force (Figures 5a and 5b). Estimates based on the method of Fridman

(1973) and for a 13m whale during a disentanglement operation differ by less than 15 kg (33 lbs).

### Discussion

Estimates of the resistance of swimming right whales are imperative to understanding their capabilities to generate force. Knowledge of their maximum swimming speed is integral in this analysis. However, this knowledge has not been reported for right whales. Several researchers have reported sustained swimming speeds (usually 24 hours or more for this species) but not burst speeds. Calculations of resistance were conducted up to a swimming speed of 10.0 m/s (20 knots). Although this speed has not been observed for right whales, it is believed that it is possible over short periods. Other large whales have been reported swimming at similar speeds. The previously discussed *O. orca* traveled in excess of 15.4 m/s (31 knots) (Johannessen and Harder 1960). Gambell (1985) reported a fin whale (*Balenoptera physalus*) attaining speeds of 10 m/s (20 knots) and Wynne (1993) reports bursts of 10.3 m/s (21 knots). Blue whales (*Balenoptera musculus*) were reported to maintain 10.3 m/s (21 knots) for ten minutes (Gawn 1948, Wynne 1993).

Aleyev's (1977) drag coefficient for a 14.0 m (46 ft) right whale is the best available. Unfortunately there were no tests to evaluate this coefficient at various Reynolds numbers. Estimates of this drag coefficient for other sized large whales, however, were similar, varying from 0.003 to 0.005 (Aleyev 1977). In order to determine this coefficient more exactly it would be necessary to conduct model tests, varying the size of the animal and speed of towing to relate the drag coefficient as a function of the Reynolds number.

Calculations based on the methods of Fridman (1973) are sound in theory. Unfortunately the only example of a marine mammal tractive force measurement was made of a dolphin by Shuleikin (1953). It may be argued that the X factor for a dolphin may not apply to right whales or other large whales, but is the best available value. The tractive force estimates calculated for right whales lie within those calculated based upon resistance while swimming, corresponding to speeds of about 8.5 m/s (17 knots). In order to refine the value of the X factor it would be necessary to evaluate through experiments the tractive force of other, preferably larger marine mammals of known length and weight.

Refinements of the length-weight relationships for right whales may aid in future studies and calculations. The use of non-linear regression provides better and more valuable estimates than linear transformations.

Evaluations of the drag of objects towed by a right whale during disentanglement operations aid in understanding the force capabilities of these whales. The drag of these objects is dependant upon the speed of towing. The resistance applied by the engines was approximately 1000 kg (2205 lbs). The values of tractive force necessary to tow these objects at slower speeds, when combined with the animals resistance at that speed are still below the animals resistance at 10.0 m/s (20 knots). Thus, it seems that this instance is not an exceptional display of force, but rather an expected capability.

Estimates of right whale tractive forces calculated by these methods provide some direction toward the a solution to the entanglement problem. When evaluating regulations for gear strength it is necessary to evaluate what size individuals will be

present in each fishing area. The number of individuals of each size is definitely not equal. Since right whales grow quickly, the number of individuals less than 10-12 m (33-39 ft) in length may be small, relative to the number of larger animals. For areas which have a larger number of small individuals, such as calving grounds, weaker breaking strengths may be necessary to prevent entanglement. In other areas where larger whales are more prevalent, stronger lines may be used.

The behavior of these whales around fishing gear and lines also needs to be considered. The probability of observing the initial encounter and entanglement is unlikely, thus hypotheses of entanglement mechanisms must be developed from existing photographs, observations and information. Behavior becomes a particularly important variable if it results in a whale not fully utilizing its force capabilities. The force generated by a freely swimming whale may vary significantly in entanglement situations. It is possible that pain stimuli may impede the generation of force.

### **Summary, Conclusions, and Recommendations**

Determination of the tractive force of the right whale is necessary to improve the safety of whales in areas of extensive fixed-gear fisheries. By estimating the whale's tractive force, it is possible to evaluate what breaking strengths the surface lines of fishing gear must be in order to ensure the safe escape of a whale. Additional calculations obtained from experimental model tests, as well as actual measurements made on whales would significantly increase the accuracy of these calculations.

Estimates of the tractive force of large whales were developed to better understand the interaction between whales and fixed fishing gear. To facilitate these calculations,

information on the swimming kinematics of other marine mammals was examined. Several models of the propulsive forces generated by large whales based on drag, size, and swimming speed. Maximum propulsive force estimates for the Northern right whale ranged from 211 kg (465 lbs) for 4 m whales to 4,282 kg (9,440 lbs) for 18 m whales, at 10.0 m/s (20 knots). Maximum estimates of tractive force determined by the method of Fridman (1973), ranged from 61 kg (135 lbs) to 3161 kg (6969 lbs) for the same species and size range. A minimum tractive force estimate, based upon the resistance of a towed vessel and gear during a disentanglement operation of a 12 m Northern right whale, was comparable to the theoretically derived estimates.

Further improvement of these estimates requires testing of actual fishing gear, using model test and field experiments, scrutinized by complex calculations. This will enable a complete understanding of both the whale's reaction during an encounter with fixed fishing gear, as well as an understanding of the dynamic forces that are applied to the fishing gear during the encounter.

#### **Acknowledgments**

We thank the National Marine Fisheries Service for providing financial support. We thank: Drs. John Lien and Neil Bose, for their research advice, Robert Kenney for his input on the behavioral characteristics of the right whale, Captain John Our for his accounts of rescue operations, and Dr. John Williams for his assistance in mathematical formulations.

## References

- Aleyev, Y.G. 1977. Nekton. Junk, W. Publishers—The Hague. pp. 435.
- Anonymous. 1997a. CCS To The Rescue. Center for Coastal Studies. Provincetown Village. (<http://www.wn.net>).
- Anonymous. 1997b. Field season synopsis: right whale surveillance and management Program. Center for Coastal Studies. Provincetown Village. (<http://www.wn.net>).
- Beach, D. 1997. Northeast region strategy for implementation of The Large Whale Take Reduction Plan. National Marine Fisheries Service.
- Bose, N., Lien, J. 1989. Propulsion of a fin whale (*Balaenoptera physalus*): why the fin whale is a fast swimmer. Proceedings of the Royal Society London, Great Britain. B237: 175-200.
- Bose, N., J. Lien, J. Ahia. 1990. Measurements of the bodies and flukes of several cetacean species. Proceeding of the Royal Society of London. Great Britain. B242: 163-173.
- Brown, M, S. Kraus, D Gaskin. 1991. Reaction of North Atlantic right whales (*Eubalaena glacialis*) to skin biopsy sampling for genetic and pollutant analysis. In Genetic Ecology of Whales and Dolphins. (Ed. By A.R. Hoesel) Report of the International Whaling Commission, Cambridge. Special Issue 13; pp. 84-89.
- Curren, K. 1994. Swimming kinematics of a harbor porpoise (*Phocoena phocoena*) and an Atlantic white-sided dolphin (*Lagenorhynchus acutus*). Marine Mammal Science. 10(4):485-492.



- Fridman, A.L. 1973. Theory and design of commercial fishing gear. Translated from Russian for NMFS, Jerusalem. pp. 489.
- Gambell, R. 1985. Fin whale (*Balaenoptera physalus*). In: Handbook of Marine Mammal (Eds. S.H. Ridgeway and R. Harrison). Toronto, Ontario: Academic Press. Pp 3171-3192.
- Gone, R. 1948. Aspects of locomotion of whales. Nature. 161:44.
- Hui, C. 1987. Power and speed of swimming dolphins. Journal of Mammalogy. Vol. 68, pp. 126-132.
- Huntley, A., G. Costa, J. Worthy, and M. Castellini. 1987. Approaches to marine mammal energetics. Society for Marine Mammalogy. Allen Press, KS, USA. pp. 115-145.
- Johannessen, C., J. Harder. 1960. Sustained swimming speeds of dolphins. Science. 132:1550-1551.
- Jones, S. 1997. Rescuers track entangled right whale; deadline nears for comments on plan. Commercial Fisheries News. 25(2); 16a-17a.
- Kramer, M. 1960. The dolphins secret; boundary layer stabilization distributed dumping. J. American Society of Naval Engineers. 72(1): 74(2).
- Kenney, R. 1997. Personal communication. Marine mammal research scientist. University of Rhode Island: Graduate School of Oceanography, Narragansett, RI.
- Lang, T. 1966. Hydrodynamic analysis of cetacean performance. In: Whales Dolphins and Porpoises. Ed. K.S. Norris. Berkeley; University of California Press. pp. 410-432.

- Mate, B., S. Nieukirk, R. Mesecar, T. Martin. 1992. Application of remote sensing methods for tracking large cetaceans: North Atlantic right whales (*Eubalaena glacialis*). Oregon State University, Newport Oregon; pp. 48-49.
- McCaffrey, J. 1997. Commonwealth proposes rules to protect endangered whales. Massachusetts--Conservation Director. (<http://www.world.std.com>).
- Omura, H. 1957. Report on two right whales caught off Japan for scientific purposes under Article VIII of the International Convention for the Regulation of Whaling. Norsk Hvalfangsttid. 46: 374-90.
- Omura, H. 1958. North Pacific right whale. Sci. Rep. Whales Research Institute. 13: 1-52.
- Omura, H., S. Ohsumi, T. Nemoto, K. Nasu, T. Kasuya. 1969. Black right whales in the North Pacific. Whales Research Institute, Tokyo, Japan. Sci. Rep. Whales Research Institute. 23: 71-81.
- Our, J. 1997. Personal communication. Captain of F/V Miss Fitz.
- Rogers, J. 1997. Taking of marine mammals incidental to commercial fishing operations; Atlantic Large Whale Take Reduction Plan Regulations. Department of Commerce. 62(140): 39157-39188.
- Schiele, E. 1997a. Living On The Edge: The Most Endangered Great Whale. Stellwagen Soundings. (<http://vineyard.er.usgs.gov/index.html>).
- Schiele, E. 1997b. Right whale migrations. Stellwagen Soundings. (<http://vineyard.er.usgs.gov/index.html>).
- Shuleikin, V. 1953. Physics of the sea. Academy of Sciences, Moscow, published in Russian.

Томилин А,Г, 1969. Дельфины служат человеку, Наука, Москва,.

Waring, T., D. Palka, K. Mullin, J. Hain, L. Hansen, K. Bisack. 1997. NOAA Technical Memorandum NMFS-NEFSC--US Atlantic and Gulf of Mexico Marine Mammal Stock Assessments-1996. U.S. Department of Commerce. pp. 1-18.

Wynne, K. 1993. Guide to Marine Mammals of Alaska. Alaska Sea Grant College Program (MAB-44).

a)

Swimming Speed (m/s)	Length of Whale (m)							
	4.00	6.00	8.00	10.00	12.00	14.00	16.00	18.00
1.00	2.1	4.7	8.4	13.2	19.0	25.8	33.7	42.7
2.00	8.4	19.0	33.7	52.7	75.9	103.4	135.0	170.9
3.00	19.0	42.7	75.9	118.6	170.9	232.5	303.7	384.4
4.00	33.7	75.9	135.0	210.9	303.7	413.4	540.0	683.4
5.00	52.7	118.6	210.9	329.6	474.6	646.0	843.7	1067.8
6.00	75.9	170.9	303.7	474.6	683.4	930.2	1215.0	1537.7
7.00	103.4	232.5	413.4	646.0	930.2	1266.1	1653.7	2092.9
8.00	135.0	303.7	540.0	843.7	1215.0	1653.7	2159.9	2733.6
9.00	170.9	384.4	683.4	1067.8	1537.7	2092.9	2733.6	3459.8
10.00	210.9	474.6	843.7	1318.3	1898.4	2583.9	3374.9	4271.3

b)

Swimming Speed (knots)	Length of Whale (ft)							
	13.12	19.69	26.25	32.81	39.37	45.93	52.49	59.06
1.9	4.7	10.5	18.6	29.1	41.9	57.0	74.4	94.2
3.9	18.6	41.9	74.4	116.3	167.4	227.9	297.6	376.7
5.8	41.9	94.2	167.4	261.6	376.7	512.7	669.6	847.5
7.8	74.4	167.4	297.6	465.0	669.6	911.4	1190.4	1506.7
9.7	116.3	261.6	465.0	726.6	1046.3	1424.1	1860.1	2354.2
11.7	167.4	376.7	669.6	1046.3	1506.7	2050.7	2678.5	3390.0
13.6	227.9	512.7	911.4	1424.1	2050.7	2791.3	3645.7	4614.1
15.6	297.6	669.6	1190.4	1860.1	2678.5	3645.7	4761.8	6026.6
17.5	376.7	847.5	1506.7	2354.2	3390.0	4614.1	6026.6	7627.5
19.4	465.0	1046.3	1860.1	2906.4	4185.2	5696.5	7440.3	9416.6

Table 1a and 1b. Propulsive force (a=kg, b=lb) of freely swimming right whales of various sizes at different speeds. See also Figures 2a and 2b.

a) Object	Towing Speed (m/s)	
	2.06	1.03
Norwegian Balls	34.8	8.71
8 ft Sea Anchor	124	31.00
Miss Fitz Hull	21.3	13.00
Miss Fitz Engines in Reverse	NA	1000
Resistance of Whale	89.1	22.3
Total Possible Drag	269.2	1075.0

b) Object	Towing Speed (knots)	
	4.0	2.0
Norwegian Balls	76.7	19.2
8 ft Sea Anchor	273.4	68.3
Miss Fitz Hull	47.0	28.7
Miss Fitz Engines in Reverse	NA	2204
Resistance of Whale	196.4	49.2
Total Possible Drag	593.5	2369.4

Table 2a and 2b. Estimation of drag forces (a=kg, b=lb) involved during right whale disentanglement effort.

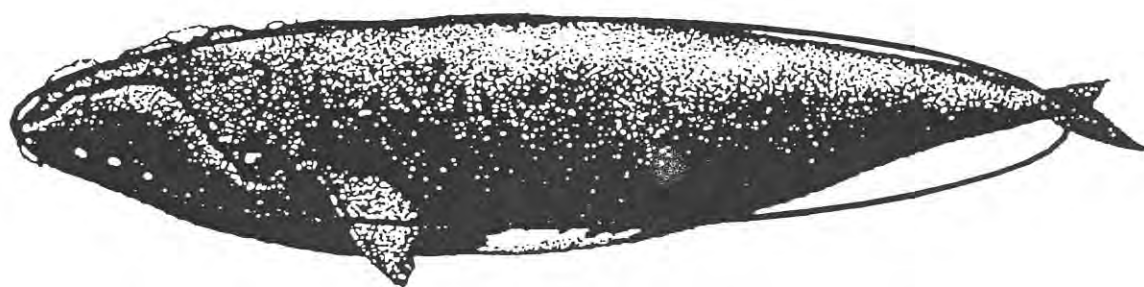
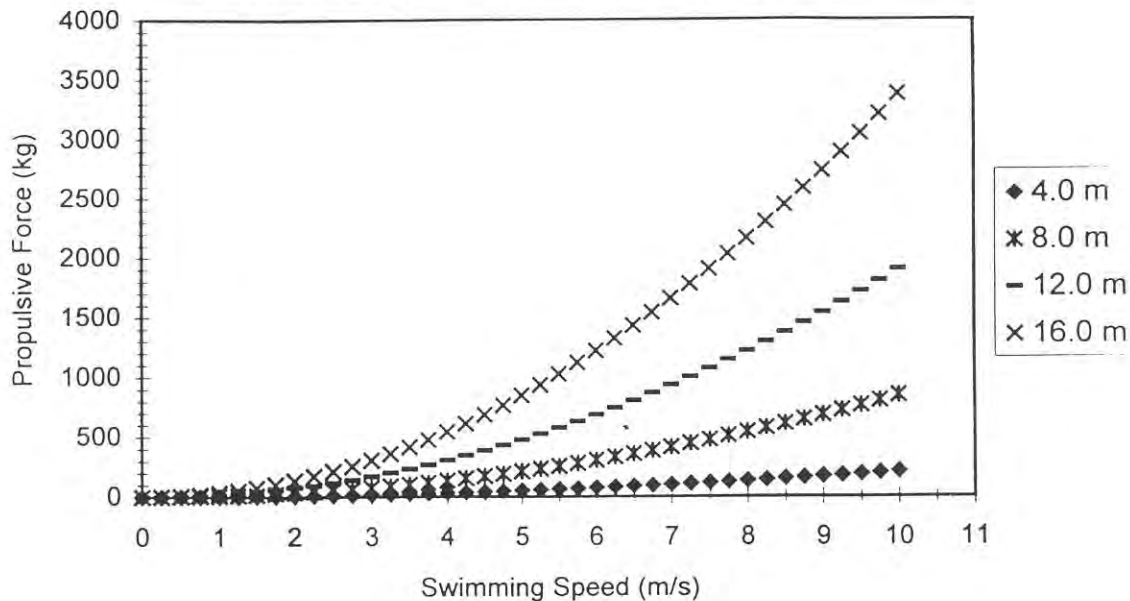

Figure 1. Right whale (*Eubalena glacialis*) with ellipse of thickness ratio,  $U=0.201$ , superimposed. Drawing by Janet Biondi.

a) Propulsive Force of Freely Swimming Right Whales (*Eubalaena glacialis*) of Different Lengths



b) Propulsive Force of Freely Swimming Right Whales (*Eubalaena glacialis*) of Different Lengths

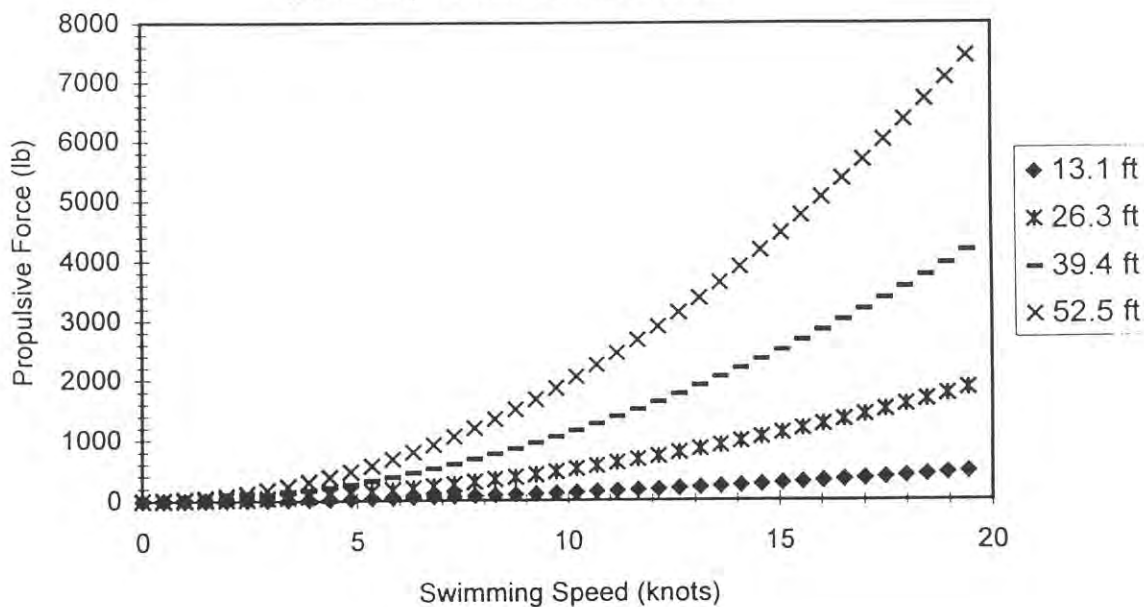

Figure 2a and 2b. Propulsive force (a=kg, b=lb) of freely swimming right whales of various sizes at different speeds. See also Tables 1a and 1b.

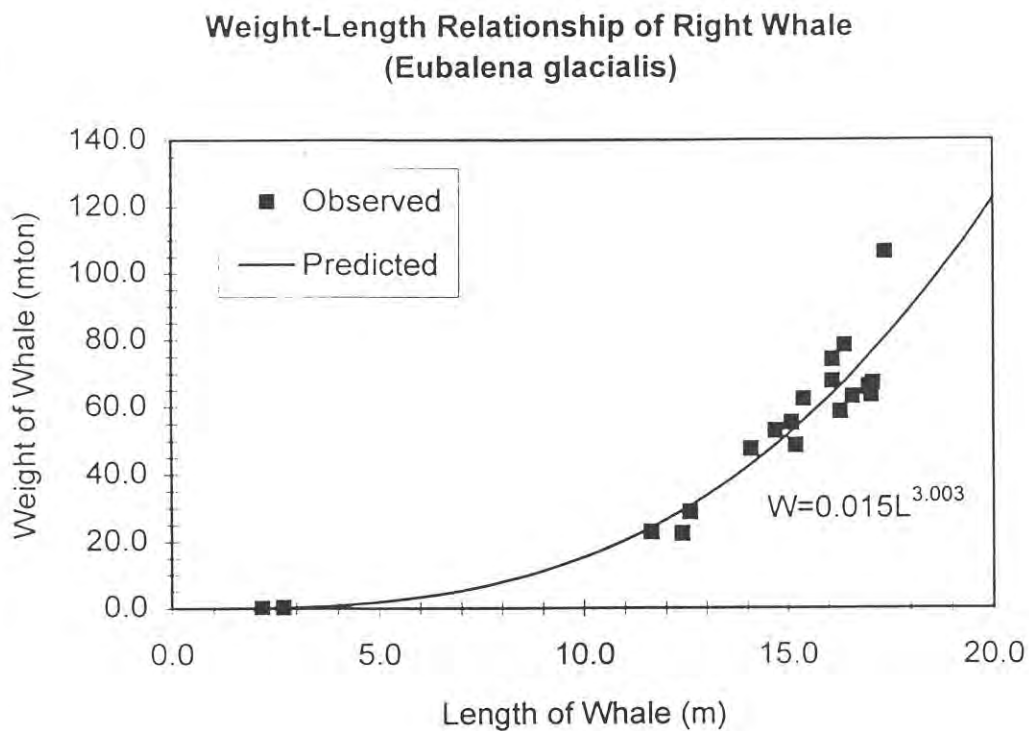
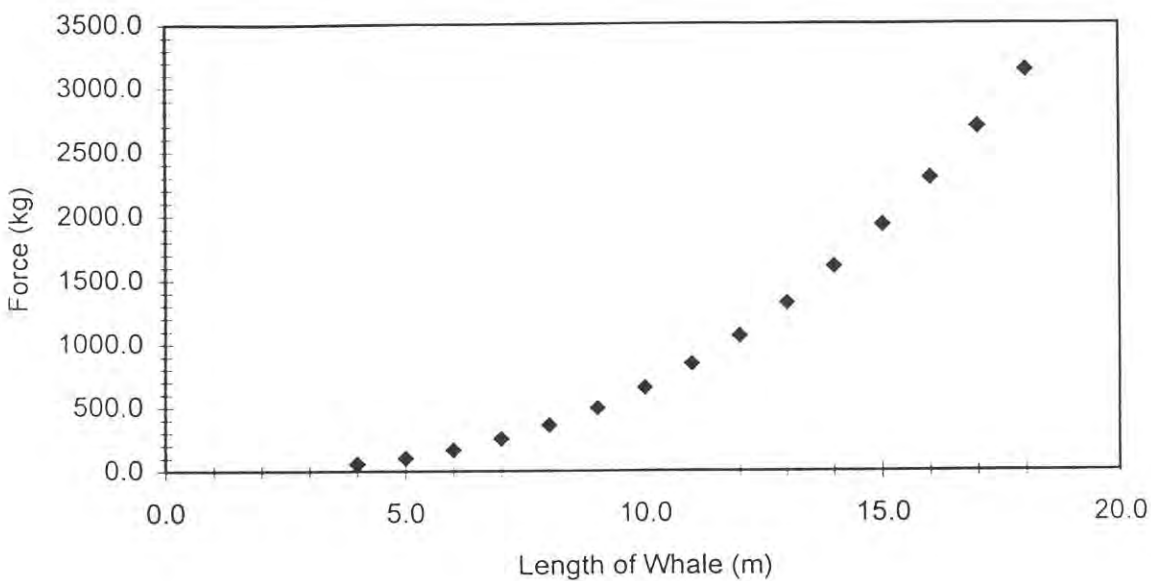

Figure 3. Weight-length relationship of right whales. Observed values from Omura et al. (1969). Predicted line and corresponding equation determined by non-linear least squares regression.



a) Estimates of Maximum Tractive Force of Right Whales as Determined by Size (Fridman 1973)



b) Estimates of Maximum Tractive Force of Right Whales as Determined by Size (Fridman 1973)

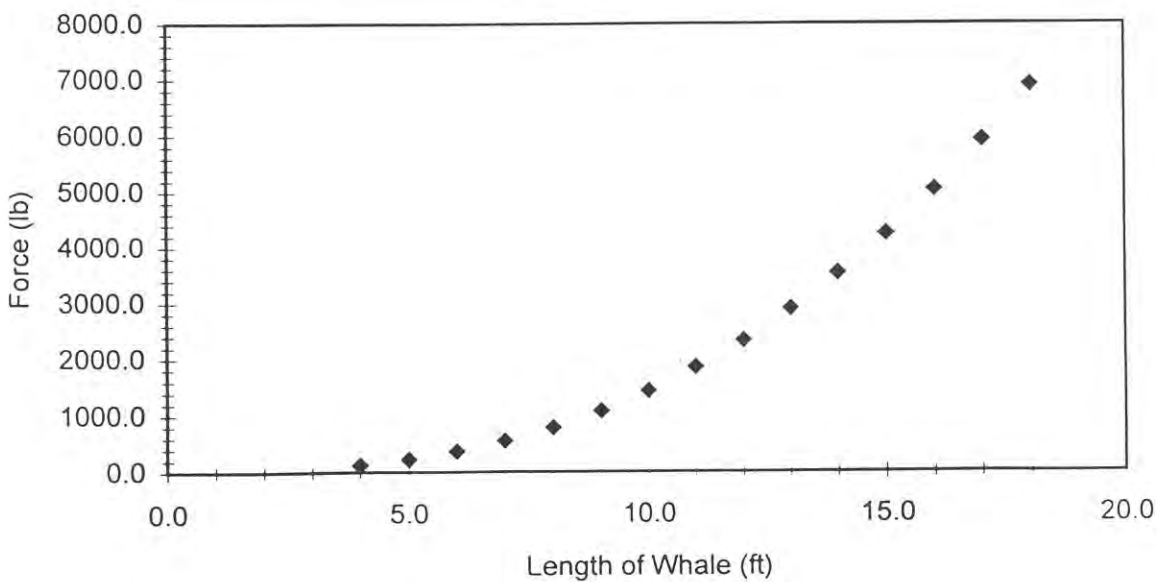

Figure 4a and 4b. Estimates of  $R_{max}$  (a=kg, b=lb), based on the similarity analysis methods of Fridman (1973), for various sizes of whales.

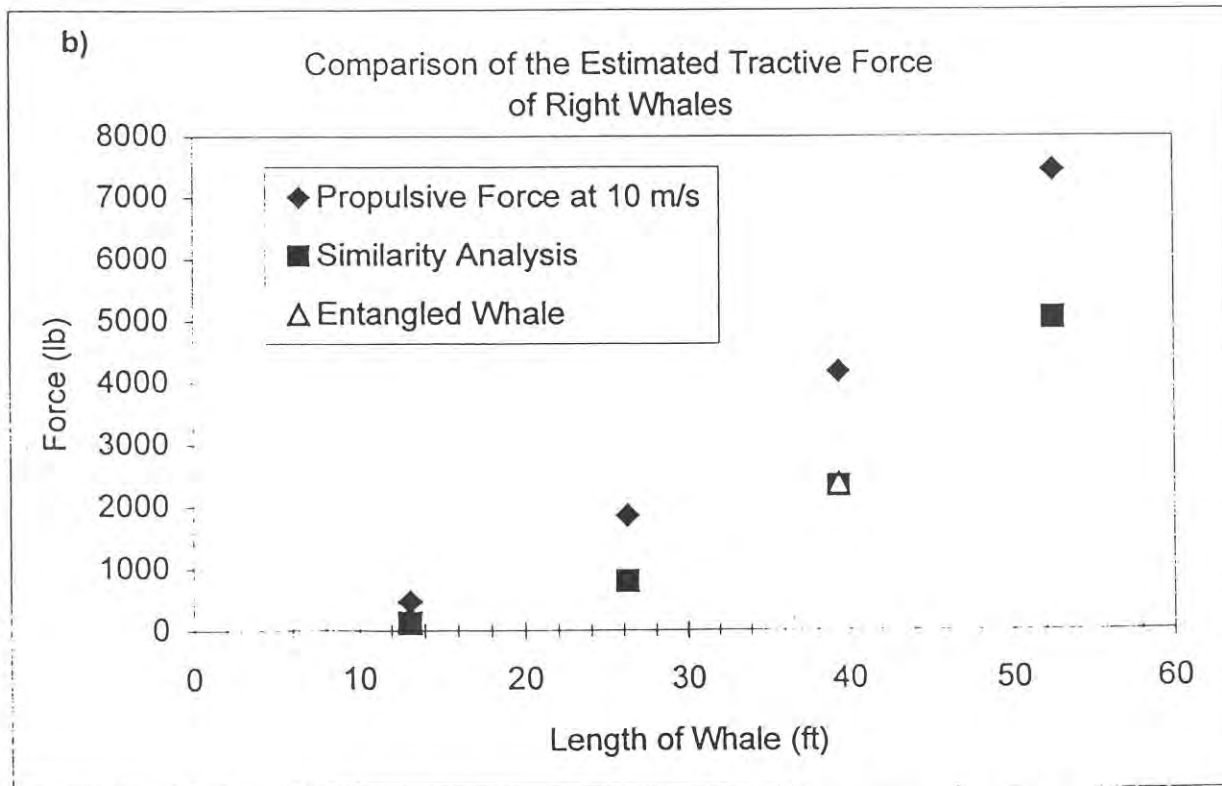
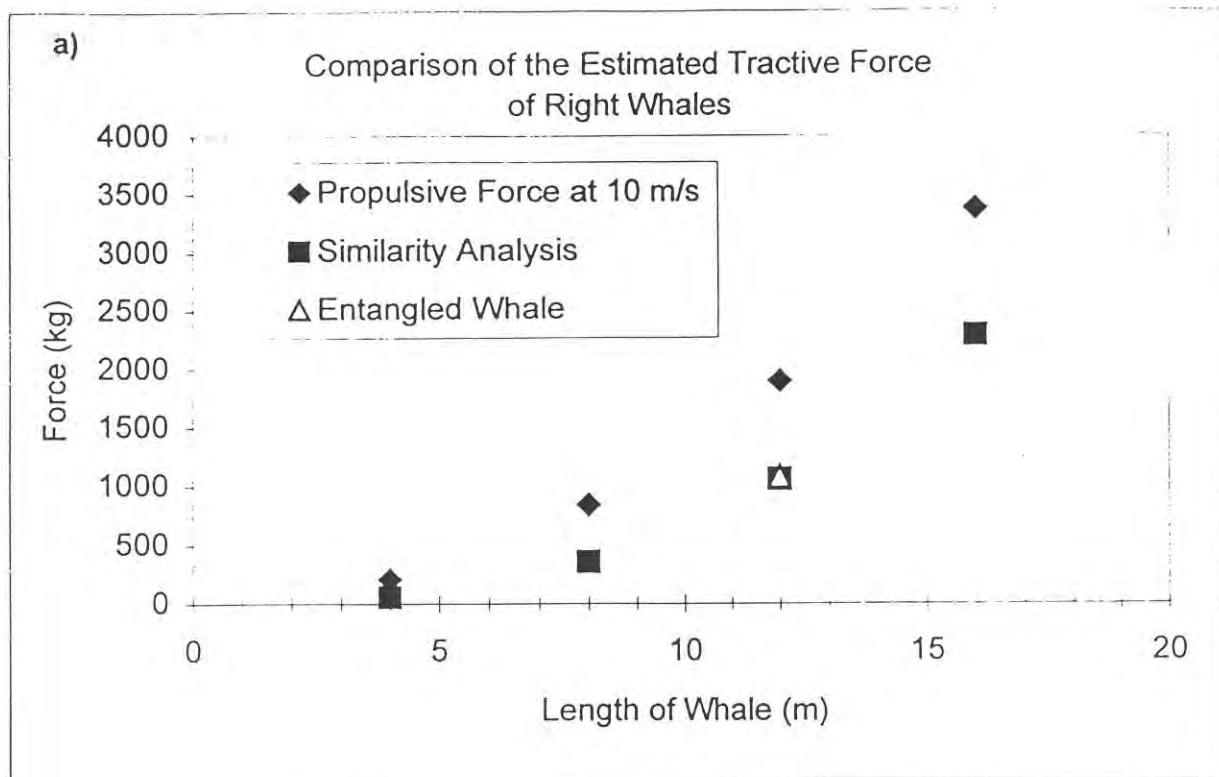

Figure 5a and 5b. Comparison of three methods of estimating tractive force (a=kg, b=lb) of right whales of different size.

## Gear Retrieval Utilizing Light Buoy Line

November, 21 2000

Gear Research Team  
Protected Resources Division  
NMFS, Northeast Region

There are a variety of methods & techniques that could be employed to fish lobster gear with a light buoy line (strength of 300 – 500 pounds) between the gear and the surface buoy.

A light buoy line or 'tag' line would run from the surface buoy down to the gear. The bottom end of the tag line would be attached to a 'hauling' line. The bottom end of the tag line would also be attached directly to the gear in such a way that a minimum force needs to be exerted through the tag line before the hauling line is released (30 to 50 pounds\*). This minimum force is to insure that the hauling line is not released due to weather & sea conditions before the fisherman intends to haul the gear. The hauling line is then brought to the surface and the gear hauled.

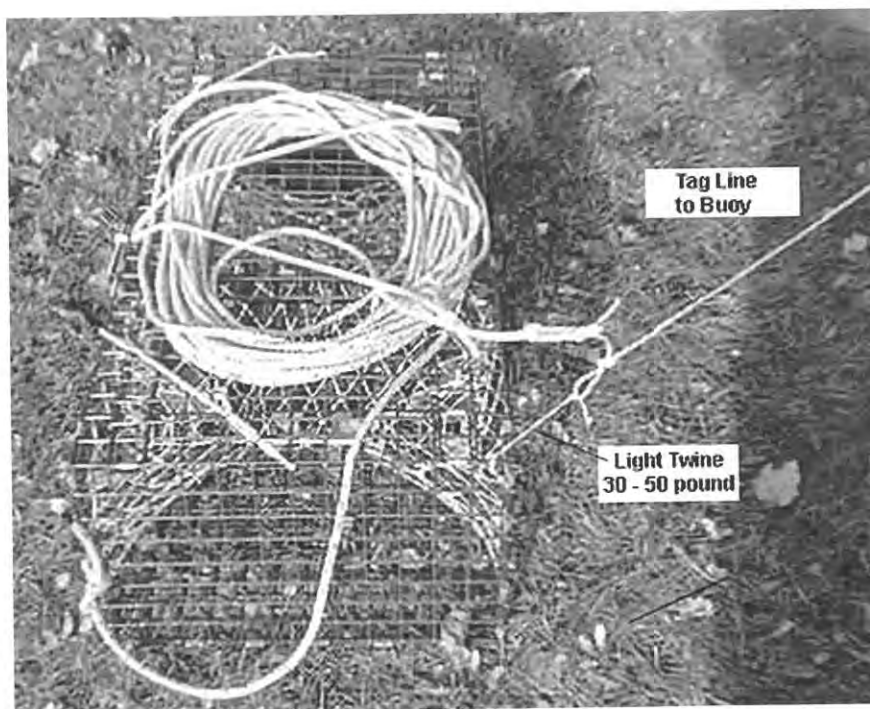

Techniques for storage of the hauling line might include: coiling and securing the hauling line to the trap with light twine (kite string), coiling and securing the hauling line with elastic tiedowns, loading the hauling line into a container attached to the gear from which it could then be pulled.

Our research indicates that knots in 1/4" diameter and smaller rope would not significantly increase entanglement risks. Also, given that the tag line strength is limited, the use of knots in the tag line for attaching to the hauling line could be allowed.

**Variations:**

Biodegradable tag line – Manila, Cotton, Sisal, etc. Tests we conducted on samples of cotton and sisal rope exposed to the salt water environment showed a reduction in strength of approximately 50% in a 5 month period.

Back-up buoy - Provide a small buoy at the upper end of the hauling line to facilitate recovery of the gear in the event the tag line parts before the hauling line reaches the vessel.

Release trigger - Have the light buoy line act as a release trigger for the hauling line and buoy.

\* Would vary depending on surface gear and area conditions. Could use light twine or a mechanical clip.

The Design, Production and  
Sea Testing of Modern Mould Sliplink™  
Knotless System

Dan E. Paul/Modern Mould  
Gary E. Ostrom F/V Rare Bind

This is not a final report on the Sliplink™ System, but rather an update on a continued study of the effectiveness and feasibility of this type of buoy breakaways use in the fishing industry.

In June of 1997 the Atlantic Large Whale Gear Advisory Group (ALWGAG) and the National Marine Fisheries Service (NMFS), met in Peabody Massachusetts to discuss modifications to the Coastal Inshore Lobster pot Fishery. These proposed modifications were to reduce the risk of whale entanglement, while continuing to allow fishing in areas that whales are known to frequent. Prior to this meeting, I had the opportunity to listen to a Massachusetts Lobstermen forum that included Dr. Charles (Stormy) Mayo from the Center for Coastal Studies (C.C.S). At that time he stated the most ideal situation for a whale to become disentangled would be a line without any knots or restrictions. That is the concept behind our Knotless buoy Sliplink™ System.

The Sliplink™ uses a jam kлят theory with the excess line approximately 6" at the bitten end to act as a clutch. This clutch allows for a series of small slips before complete separation from the buoy. The slip strength can either be increased or decreased simply by adding or subtracting the number and size of teeth when it is molded.

Prior to sea testing of Sliplink™ in actual lobstering conditions, a series of dry tests were conducted at the Massachusetts Maritime Academy in Bourne. These tests were performed by Ron Smolowitz - Goonamessett Farm, Dan Paul - Modern Mould, and Gary Ostrom - F/V Rare Bind. See Appendix A.

In March of 1998 I received a special experimental permit from the Massachusetts Division of Marine Fisheries (MA-DMF), to test the Sliplink™ System on my lobster gear. The reason for a special permit was because most of Cape Cod Bay had been designated a critical habitat area for Northern Right Whales from January to May. Due to critical habitat status, all lobster pots were tied in pairs, groups of 2 traps with one vertical line to the surface and one buoy. Pairs were spaced approximately 35 feet apart and placed in water depths between 4 and 12 fathoms. The first traps were set on March 17, 1998 with 150 pairs (300 traps), in the water by April 6, 1998. Traps were hauled on an average of every 4 days with all traps being hauled on each trip. This averaged out to 17 cycles of the gear multiplied by 150 pairs, or 2550 separate trap hauls by May 31, 1998. At that time all gear was accounted for except 2 pairs. One of those pairs was relocated on July 17. It had been caught on other lobster traps. It was determined that line chaffing from rocks 4 fathoms from the buoy caused the loss. The second pair has never been found and reason for the loss never determined.

As of the first week of June, 48 Sliplinks™ were removed with 100 pairs left to continue being monitored through the season. All traps were hauled on an average of every 3 days throughout the summer season with 41 cycles or 4100 pair haulings. To date, two more pairs are missing with no determination of why they have been lost. At the end of my season which is the end of January, all gear will be hauled in and losses added up. During

an average season barring any major storms, I lose to boat traffic, theft, age, etc., about 15%, or 110 traps. This will help determine if gear with Sliplink™ was lost at a higher or lower average. Major storms have been at a minimum this year, but there were times in early spring through summer and early fall with N.E. wind gusts to 60 mph, West wind gusts to 50 mph, and SW wind gusts to 35-40 mph.

Sliplink™ is still in the design modification stage with two areas to be improved on. The first area is the line locks at either end of the jam klead. They will be larger to accommodate rope easier with less chance of breaking off when rigging. The second will be to reduce the flair on the lock clip to eliminate the chance of something hanging on it and pulling it off. Both of these problems can be corrected in the final mold. It should be noted that currently I have 10 Sliplinks™ fishing without lock clips. These Sliplinks™ have been in the water since June without any failures.

In summary, although conclusions that I may draw could be construed as bias because I helped to design Sliplink™, I would like to state that I did handle buoys with this knotless system more carefully at the beginning when hauling. At the time the reason was the cost of one pair or 2 traps, line and buoy being \$88.50, with losses coming directly out of pocket. Now with months of weed growth on buoys and lines, most Sliplinks™ can't be seen and all gear is hauled the same. Trust is something that is earned over time and at this point I trust this system to hold my buoys the same as my knotted gear.

**Appendix A**  
Slipping Link - Missing Link Testing

Test/Strength 1/28  
5/16 Nylon Rope

---

Test 1: 5/16 Rope  
Small teeth (first samples)  
Load: 290 lbs Max

Test 2: 5/16 Rope  
Large teeth (second samples)  
Load: 420 lbs

Test 3: 5/16 Rope  
Large teeth (second samples)  
Load: 420 lbs

Test 4: 5/16 Rope  
Small teeth (first samples)  
Load: 277 lbs

Test 5: 5/16 Rope  
Large teeth (second samples)  
Load: 320-340 lbs

Test 6: 5/16 Rope  
Large teeth (second samples)  
Load: 390 lbs (300 after)

Test 7: 5/16 Rope  
Large teeth  
Load: 330 lbs

Test 8: 5/16 Rope  
Large teeth  
Load: 416 lbs

Test 9: 5/16 Old rope  
Large teeth  
Load: 378 lbs

Test 10: 5/16 Old rope  
Large teeth



Load: 391 lbs  
Broken clips - 6

Test 11: 5/16 Old rope  
Small teeth  
Load: 226 lbs

Test 12: Rope Strength  
Old rope: 720lbs  
New rope: 694 lbs

# M.M. Slip Link

5/16" E-Z Haul ; Taped End  
NMFS Kingston, RI

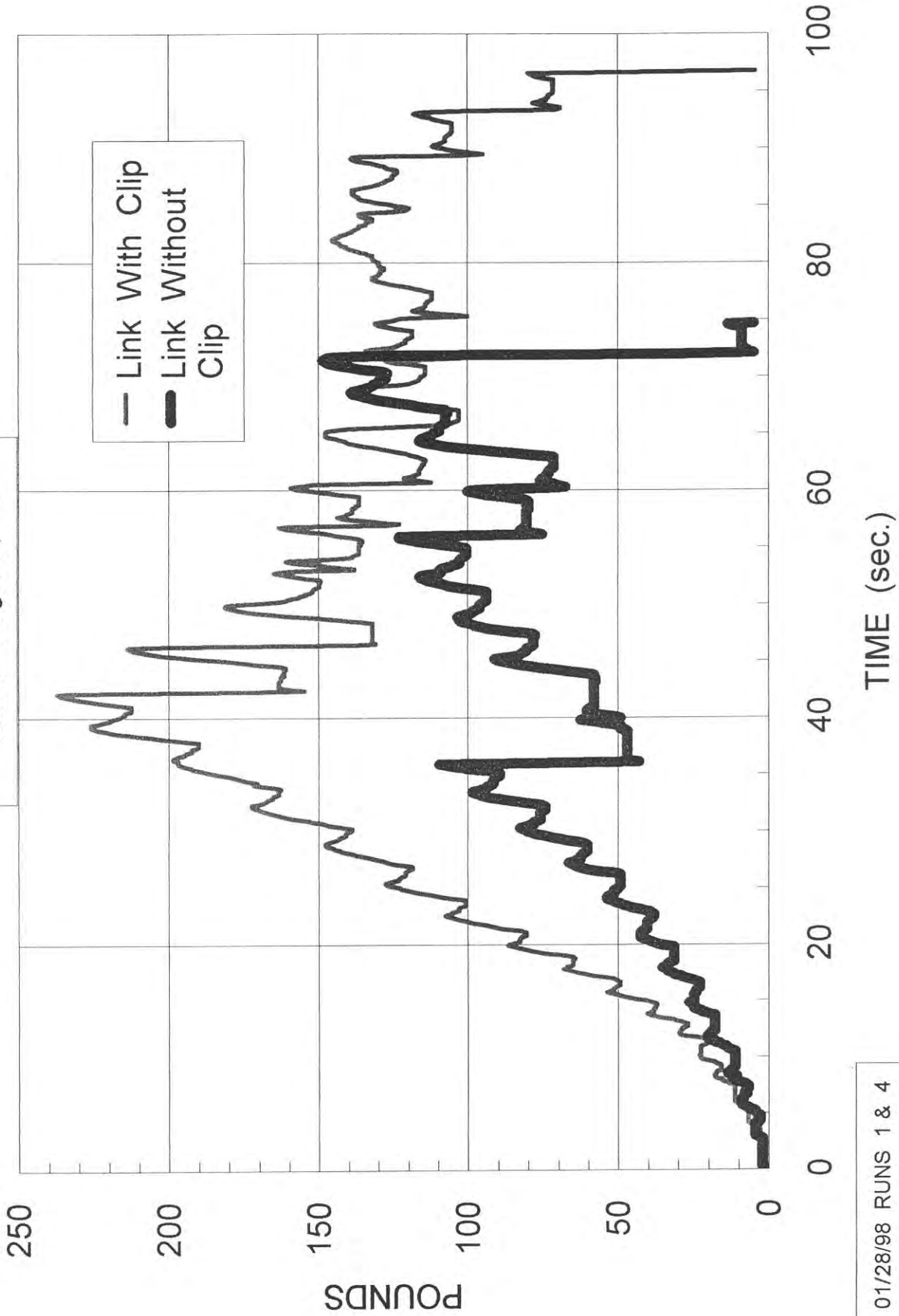

— Link With Clip  
— Link Without Clip

01/28/98 RUNS 1 & 4

M. M. Slip Link w/Clip  
5/16" Rag Rope : Taped End  
NMFS - Kingston, RI

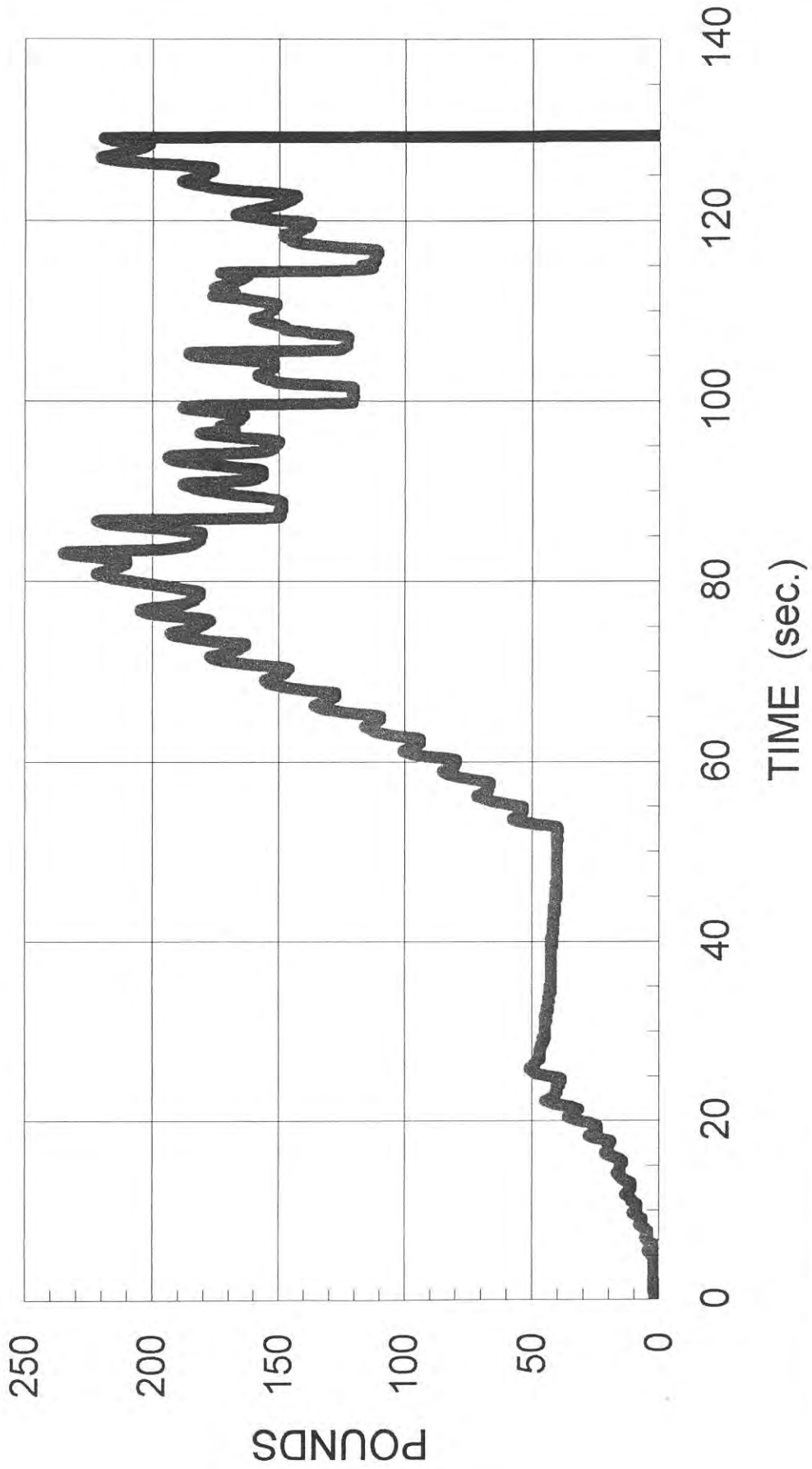

01/28/98 RUN 10

M. M. Slip Link w/Clip  
5/16" Rag Rope : Cut End  
NMFS - Kingston, RI

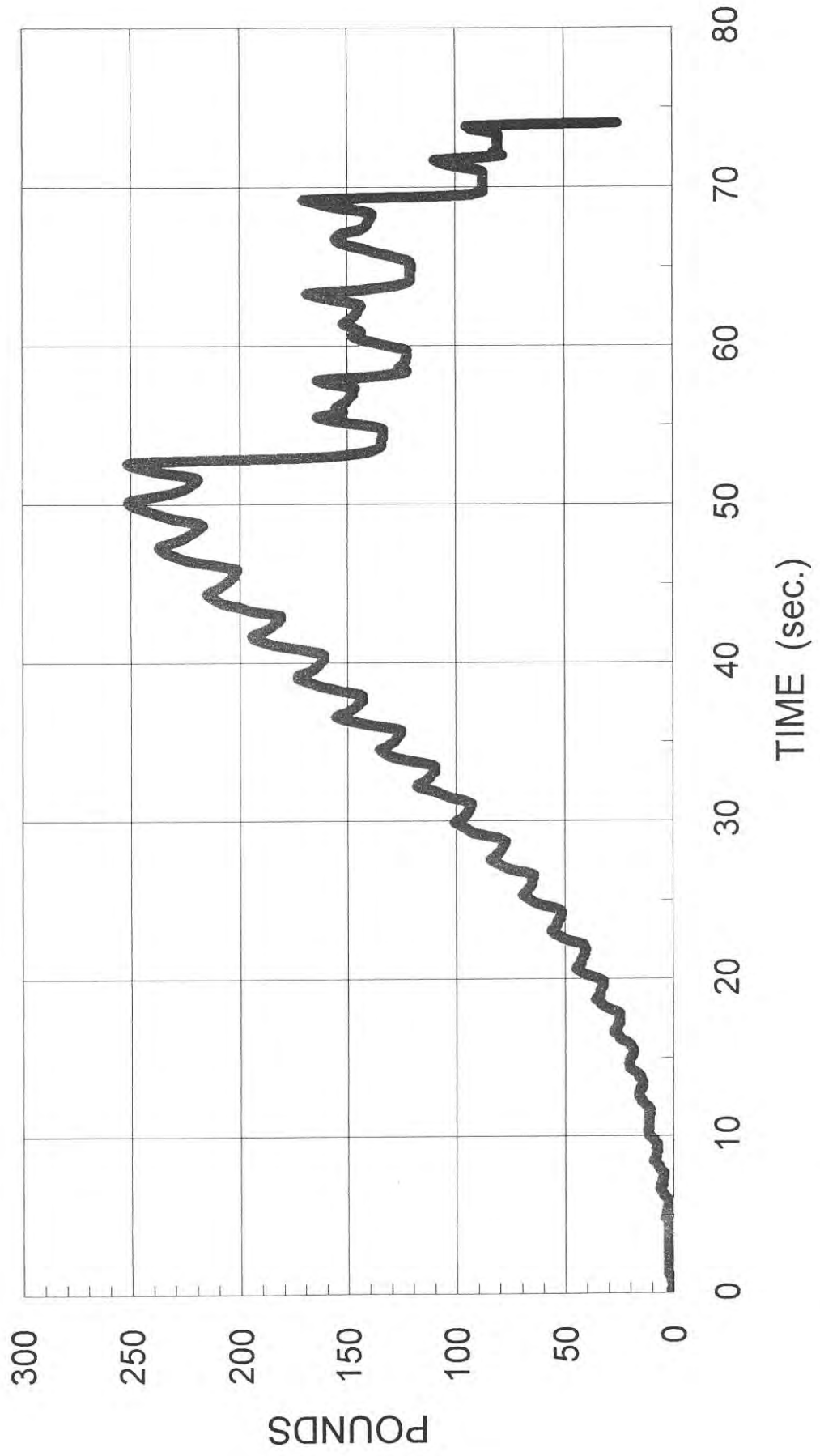

01/28/98 RUN 11

**COLLABORATIVE RESEARCH TO DESIGN MODIFICATIONS OF  
FIXED FISHING GEAR FOR REDUCING THE RISK AND  
CONSEQUENCES OF RIGHT WHALE ENTANGLEMENT**

**David Wiley**<sup>1</sup>: International Wildlife Coalition, 70 East Falmouth Highway, East Falmouth, MA

**Ronald Smolowitz**: Coonamessett Farms, Hatchville, MA

**Robert MacKinnon**: 65 Elm Street, Marshfield, MA

**Scott MacKinnon**: 53 Texas Street, Marshfield, MA

Funded by:

**Massachusetts Environmental Trust**

New Alliances Program

33 Union Street, 4<sup>th</sup> Floor

Boston, MA 02108

<sup>1</sup> Present address: Stellwagen Bank National Marine Sanctuary, 75 Edward Foster Road, Scituate, MA

## INTRODUCTION

The project involved the development and testing of innovative fishing gear modifications designed to reduce the risk and consequences of large whale entanglement. All devices were land tested to determine breaking strength and operationally tested at sea to ensure that they could be used by fishermen. All devices were designed by Bob MacKinnon, a gillnetter from Scituate, MA. At sea testing occurred during normal fishing activities aboard the F/V Lady Irene, a 44' Novi gillnetter owned and operated by the MacKinnon family. The devices produced and tested were the:

- **Fishermen's Knotless Line Fastener**
- **Fishermen's Weak Link for Gill Net Floatline**
- **Fishermen's Weak Link for Surface Buoy**

Our main findings were that (1) the Fishermen's Knotless Line Fastener could quickly and easily join the bitter end of two lines together without the use of a knot and withstand loads commonly encountered during fishing operations, (2) the Fishermen's Weak Link for Gill Net Floatline (land tested breaking strength of 300-400 lbs) could be operationally used to depths of at least 90 fathoms (540 ft) in strings of up to 15 nets, and (3) the Fishermen's Weak Link for Surface Buoy (land tested breaking strength of ~150 lbs) could be operationally used with polyball and high flyer set-ups throughout the year.

## FISHERMEN'S KNOTLESS LINE FASTENER -

### Need -

1) Reduced Risk of Entanglement - Right whales become entangled in buoy line of lobster and gillnet fishing gear for a variety of reasons. One scenario involves an animal encountering the line when feeding or traveling. Under most conditions, the narrow, round, and smooth structure of the line allows it to pass through the whale's mouth or past appendages such as the flippers without snagging on the whale and causing an entanglement. However, the existence of knots within the buoy line result in obstructions that increase the risk of entanglement. Currently, there exists no way for lines to be joined together without the use of a knot. This is particularly problematic within the lobster fishery because high gear densities cause fishermen to set gear in close proximity to one another. As a result, the buoy lines from adjacent fishermen frequently become tangled. The fishermen remedy this situation by cutting the lines and rejoining them with a knot. This process occurs frequently, and most buoy lines have multiple knots along their length.

2) Increase the success of disentanglement efforts - Once a right whale is entangled, the fishing gear must be removed from its body. This removal can occur naturally or require human intervention. An impediment to both forms of gear removal is the existence of knots within the line that cause obstructions that hinder the removal of the gear. This is particularly true for entanglements that involve the whale's baleen. For example, recent rescue efforts for a right whale have been stymied because a knot in the

line will not pass through the animal's baleen. If lines did not have knots, the success of natural and human disentanglement efforts would increase.

The purpose of the Fishermen's Knotless Line Fastener is to join the bitter ends of two lines without the use of a knot. Since 1996, the Atlantic Large Whale Take Reduction Team and the Atlantic Large Whale Take Reduction Plan have placed a high priority on the creation of such a device. However, its development has proven elusive. To be effective, the device must meet the following requirements:

1. It must join the bitter ends of two lines together without leaving a knot or other obstruction that is likely to lodge in the baleen of a whale and facilitate entanglement of the animal
2. The device must be strong enough to allow fishing gear to be hauled.
3. The device must be capable of being applied at sea without substantially delaying fishing operations
4. The device must be economical.

The Fishermen's Knotless Line Fastener meets all of the above requirements.

**Description of Device** – The device consists of a 2-ft. long woven mesh tube similar to a "Japanese Finger" design. The tube consists of the sheathing or outer shell from a length of ½' poly foam-core floatline commonly used in the gillnet fishery. The tube is obtained by removing the foam center from the floatline. The bitter end of each line to be joined is inserted into opposite ends of the tube until they meet in the center (~ 1 foot). Each line is then secured to the tube by using three 1" or ¾" hog rings (6 in total). The outer two hog rings are crimped tightly around the tube and line. The center hog ring is crimped as so to penetrate both the tube and the inserted line (see Figure 1).

**Figure 1. Diagram showing the design of the Fishermen's Knotless Line Fastener used for joining two lines together without the use of a knot.** The device consists of a 2-foot long tube of woven "Japanese Finger" material. The bitter end of each line to be joined is placed into opposite ends of the tube. Six hog rings are then used to attach the tube to the lines and linking them together.

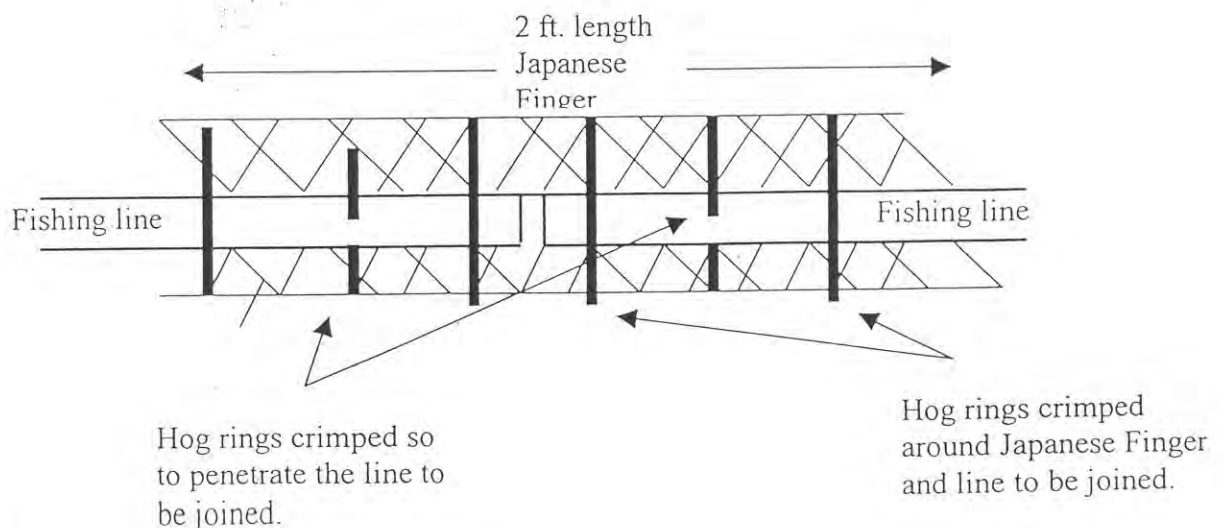

### Testing of the Fishermen's Knotless Line Fastener –

The Fishermen's Knotless Line Fastener was tested for breaking strength at the Coonamessett Farms Dry Testing Facility (Falmouth, MA) and operationally at sea aboard the F/V Lady Irene (home port Scituate, MA; owned and operated by the MacKinnon family).

1. Dry Testing - A series of land tests to determine the load capability of the device were performed at Coonamessett Farms. Gillnet fishermen, conservationists, and engineers attended the test sessions. The device failed at loads between 800 and 900 lbs. This load level is above that recorded by the Massachusetts Department of Marine Fisheries during the hauling of lobster gear in Cape Cod Bay, suggesting that the Fishermen's Knotless Line Fastener could be used in that area. However, measurement of haul forces for most other areas and gillnets have not been conducted.

2. Operational Testing - Lines joined by the Fishermen's Knotless Line Fastener have been used aboard the Lady Irene since December 2000 without failure. A copy of the data sheet used for assessing the device can be found in appendix 1.

### **FISHERMEN'S WEAK LINK FOR GILLNET FLOATLINE –**

#### Need -

Reduction of the entanglement risk posed to right whales by gillnets has been a key aspect of all recovery and take reduction plans targeting right whales. The ALWTRT recommended that weak links be placed in gillnets, thereby improving the chance that a right whale could break free of the nets before serious injury or death occurred. However, the strength and location of such links have been open to debate. Wiley et al. (1996), demonstrated that such links must be located within the gillnet panel to be effective, but were unable to provide guidance of potential breaking strengths to be used. Consequently, the ALWTRT and Gear Advisory Group (GAG) recommended weak links with a breaking strength of ~1,100 lbs be placed within the center of each net panel. A goal of all parties interested in mitigating the conflict between right whales and gillnets has been producing weak links with the lowest breaking strength that are operationally feasible for the industry.

To be effective, the device must meet the following requirements:

1. It must weak enough to substantially increase the likelihood that a right whale encountering the net could escape without serious injury or death
2. The device must be strong enough to allow fishing gear to be hauled.
3. The device must be capable of being applied at sea without substantially delaying fishing operations
4. The device must be economical



The Fishermen's Weak Link for Gillnet Floatline meets all of these requirements. Land testing of the device recorded breaking strengths of ~300 – 400 pounds, substantially lower than the current standard of 1,100 lbs. The device has been used to haul strings of gillnets fished at depths down to over 500 feet (90 fathoms) without failure. The device uses inexpensive materials and can be incorporated into gillnets at the time of hanging or at sea.

**Description of the device –**

The Fishermen's Weak Link for Gillnet Floatline consisted of a 2-foot tube of woven "Japanese Finger" material (see description contained in Knotless Fastener section). The link was created by cutting the gillnet's floatline. The resulting bitter ends were then inserted into the tubing until they met in the tube's center. Seizing twine was used to make a series of knots (see Figure 2) that secured the tube to the two ends of the floatline.

**Figure 2. Diagram of Fishermen's Weak Link for Gillnet Float Line.** The outer tube consisted of a two-foot section of "Japanese Finger" material. The float line was cut and the ends inserted into the tube until they meet at the center. Seizing twine was then used to make a series of wraps (five from either side) that rejoined the floatline.

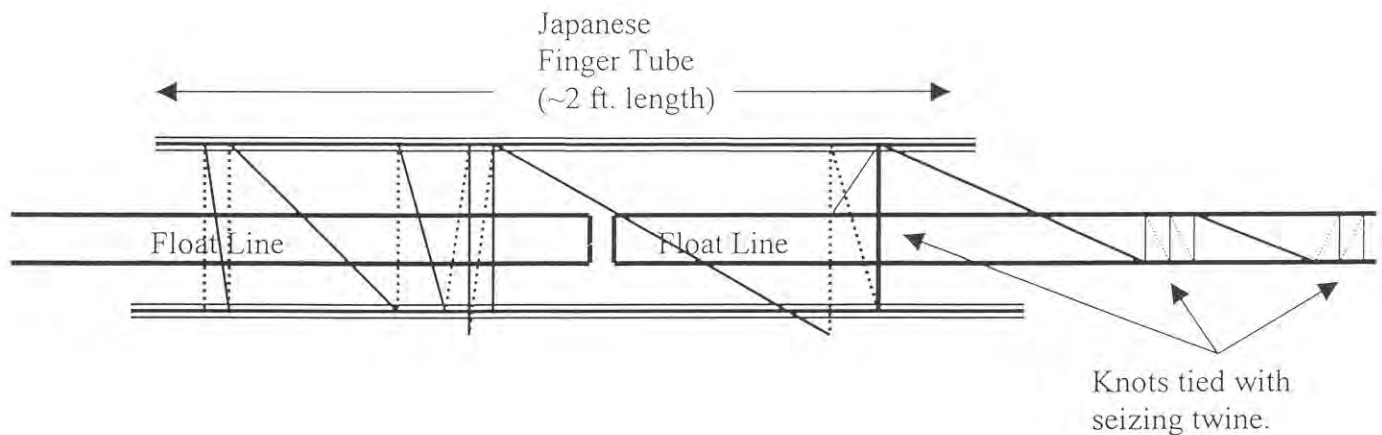

**Testing of the Fishermen's Weak Link for Gillnet Floatlines –**

The device was tested for breaking strength at the Coonamessett Farms Dry Testing Facility (Falmouth, MA) and operationally at sea aboard the F/V Lady Irene (home port Scituate, MA)

1. Dry Testing - A series of land tests to determine the load capability of the device were performed at Coonamessett Farms. Gillnet fishermen, conservationists, and engineers attended the test sessions. Limited testing determined that the Fishermen's Weak Link failed at loads of ~300 lbs. This amount is substantially below the 1,100 lb

breaking strength contained in current take reduction regulations and could prove to be of substantial conservation benefit.

2. Operational Testing - Operational Testing occurred aboard the F/V Lady Irene during normal fishing operations of the vessel. Tests occurred from December 2000 through July 2001. No Failures were recorded.

**Test Specifications for the Fishermen's Weak Link for Gillnet Floatlines:**

Gillnet Gear -

- Net:
  - Standard groundfish gillnet
- Float Line:
  - 3/8"
- Number of Nets in String
  - 8 or 15
- Location of Weak Link:
  - Center of float line

Experimental Conditions -

- Areas Fished:
  - Massachusetts Bay
  - East of Stellwagen Bank
  - South East of Gloucester, MA

- Bottom Type:
  - Rock or mud

- Water Depths:
  - Down to 90 fathoms (540 feet)

- Wind Speeds during hauling:
  - Up to 20 knots

- Wave height during hauling:
  - Up to 6 feet

**Results:**

There were no instances of the Fishermen's Weak Link for Gillnet Floatline failing during operational practice. This included one instance in which the gear hung-up on a bottom obstruction during retrieval in 6 foot seas and winds of ~ 20 knots.

## FISHERMEN'S WEAK LINK FOR SURFACE BUOYS

### Need –

Right whales are known to become entangled in fishing gear when the surface buoy becomes lodged against the mouth or acts as an obstruction that facilitates gear snagging on other parts of the body. The ALWTRT and the ALWTRP have recommended that a knotless weak link be placed just below the surface buoy. The conservation benefit would occur when the link allowed a whale encountering the buoy to break the bout from the line instead of becoming entangled.

To be effective, the device must meet the following requirements:

1. It must weak enough to substantially increase the likelihood that a right whale encountering the surface buoy would escape without serious injury or death
2. The device must be strong enough to withstand the environmental conditions encountered at sea
3. The device must be capable of being applied at sea without substantially delaying fishing operations
4. The device must be economical

The Fishermen's Weak Link for Surface Buoys meets all of these requirements.

### Description of the device-

The Fishermen's Weak Link for Surface Buoys (Figure 3) consisted of a 7' tube of 7/8" diameter PVC pipe. An opening 1/2" in diameter was drilled through the tube 3/4" from the top. A second hole 3/4" long and 5/8" wide was made in one surface of the tube centered 3 3/4" from the top of the tube. A male coupling was glued to bottom end of the tube. A flat, 3" diameter disk with an opening sized to fit over the coupling was then joined to the tube by screwing in the female portion of the coupling, thereby securing the disk to the tube. To attach the device to the fishing gear, a line fastened to the surface buoy was run through the top hole and spliced into itself, thereby securing the device to the surface buoy line. To attach the gear to the device, the line from the gear was run through the open bottom of the coupling and passed through the lower hole made in the surface of the tube. This line was then fastened to the surface buoy line with two 3/4" hog rings spaced 7.5 inches apart.

**Figure 3. The Fishermen's Weak Link for Surface Buoys.** The device is designed to allow the surface buoy to break away from the buoy line if it is encountered by a right whale. Breaking strength is ~150 lbs. Operational testing has resulted in no failures.

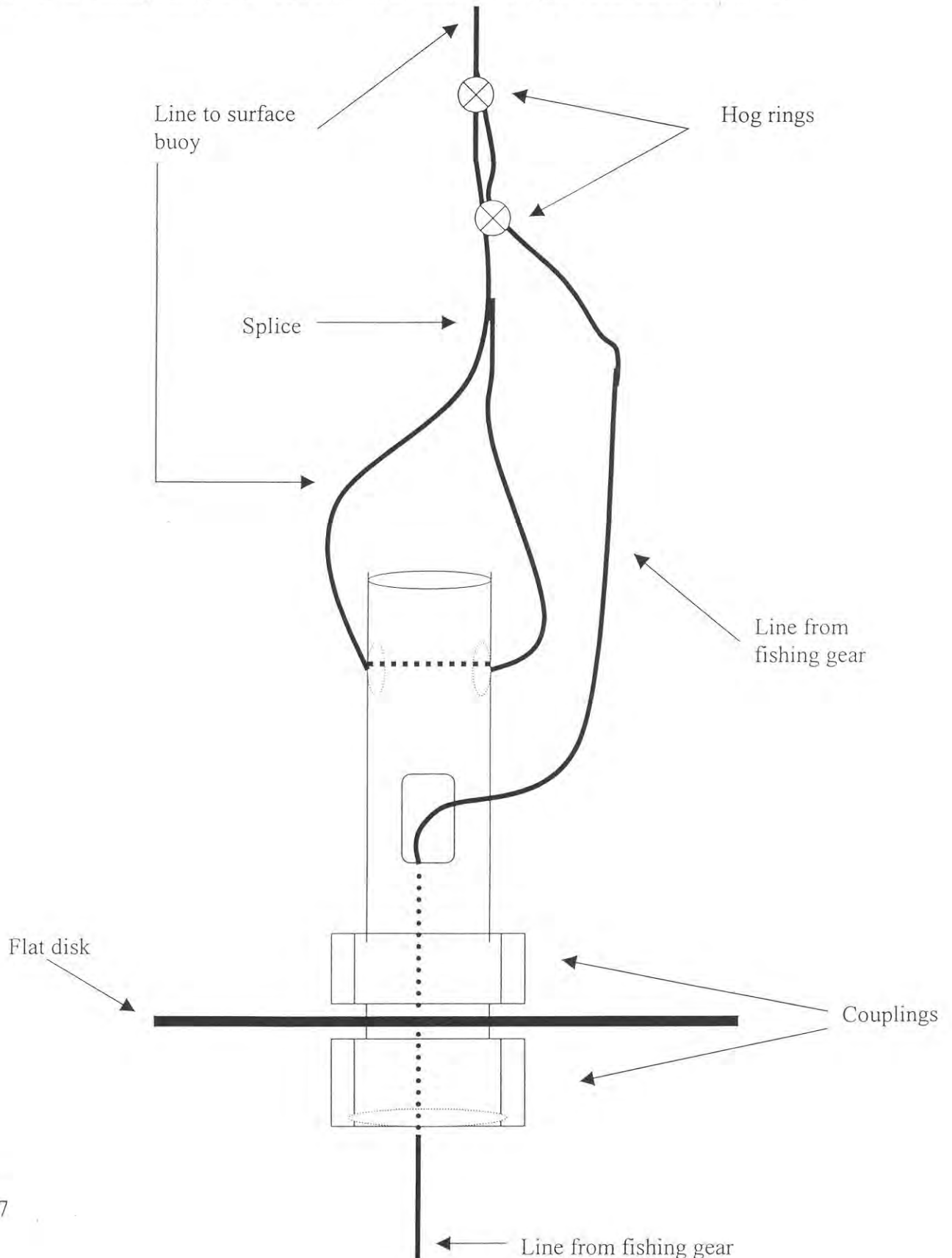

## OTHER RESEARCH EFFORTS

Several other avenues of research were explored without success. These included the following:

- 1) The development and deployment of a device to measure the inclination of gillnets on the seabed
- 2) The development of low strength line for use as the floatline of a gillnet.

### 1. Development and deployment of a device to measure the inclination of gillnets on the seabed –

Considerable debate between conservation and fishing interests centered on the degree of risk posed to whales by gillnets. Conservation interests described gillnets as a wall of netting extending 12 feet above the sea floor. Fishing interests described nets as usually laying near the sea floor because of the force of tide or other currents acting on them. Under a previous MET grant (Wiley et al 1996), we had helped develop such a device, but had not been able to deploy it. In addition, both fishing and conservation interests felt the original device needed to be modified to include a way to measure the currents acting on the nets<sup>1</sup>.

We arranged collaboration between gillnetters, conservationists, and the Massachusetts Department of Marine Fisheries to test the device. Testing was accomplished aboard the F/V Lady Irene and involved the deployment of a remotely operated vehicle (ROV) to videotape the nets that were being recorded by the device. Videotape revealed that the device's current meter became entangled in the gillnet during setout. This caused the data recorded by the device to be unreliable. Efforts to correct the problem were unsuccessful and the project was discontinued.

### 2. The Development of low strength line for use as the float line of a gillnet -

Considerable debate between conservation and fishing interests involved the placement of weak links within the float line of the gillnet. One option would be to reduce the strength of the entire float line, instead of relying on weak links inserted into it. To investigate this option, we developed collaboration between a cordage manufacturer (New England Rope, Fall River, MA), gillnetters out of Chatam, MA, and conservationists. Our agreed upon goal was to develop a line that was the diameter of line currently being used by the fishing community<sup>2</sup>, but had a breaking strength of ~1,000 lbs.

While initially optimistic, New England Rope ran into technical difficulties that were insurmountable within the parameters of the project New England Rope was

---

<sup>1</sup> The original device contained only instruments for measuring depth and inclination of the nets.

<sup>2</sup> Line of the standard thickness (3/8") was needed because the hauling equipment aboard gill net vessels was designed for lines of that diameter and smaller diameter lines posed an operational hazard.

contributing all technical expertise and materials for the research and development. After trying five different techniques, the corporation decided the engineering problem would require greater input than they could donate. The major problem was that as the line was made weaker, it became more elastic. Gillnet fishing requires line that has only a limited amount of stretch when a load is placed on it. This is because the net must maintain its designated hanging ratio and because the recoil from a stretched rope that breaks poses a hazard to those using it.

Data Sheet

MacKinnon Weal Link Test

To be filled out after hauling each string equipped with weak link

Date: \_\_\_\_\_

General Location:

Mass Bay  
East of Stellwagen  
Back Side  
GSC  
Block Island

Wind Speed:

0 - 10  
10 - 20  
20 - 30  
+30

Wind Direction:

N  
E W  
S

Wave Height (ft):

0 - 3  
3 - 6  
6-10  
+10

# Nets in String: \_\_\_\_\_

Float Line Diameter:

3/8  
1/2  
7/8

Water Depth (fathoms): \_\_\_\_\_

Bottom Type:

Sand  
Mud  
Rock

Did gear hang-up during haul-back?

Yes  
No

Did weal link in float line fail during fishing process?  
IF YES, describe the failure -

YES NO

Did weak link at buoy fail during fishing process?  
If YES, describe the failure -

YES NO